



# Axial Piston Pumps

Series P2 / P3  
Variable Displacement

aerospace  
climate control  
electromechanical  
filtration  
fluid & gas handling  
**hydraulics**  
pneumatics  
process control  
sealing & shielding



ENGINEERING YOUR SUCCESS.

<b>Description</b>	<b>Page</b>
Technical Information.....	3
Ordering Code.....	4
Control Options “PA”.....	6
Control Options “RA”.....	7
Control Options “LA” and “LB”.....	8
Control Options “TA”, “TB”, “TC” and “TD”.....	9
P2 Typical Torque Control Characteristics.....	10
P3 Typical Torque Control Characteristics.....	11
Hydr. Generated Noise / Performance Curves.....	12
Ripple chamber.....	12
<b>P2 Performance data</b>	
P2 Noise characteristics at max./min. displacement.....	12
P2 Series - typical drive power at full displacement.....	13
P2 Series - typical compensated input power.....	14
P2 Series - typical efficiency at full displacement at 1800 rpm.....	15
P2 Series - typical flow vs. pressure.....	16
P2 Series - typical compensated case drain flow.....	17
P2 Series - typical inlet characteristics vs. speed at various percentage displacements.....	18
<b>P2 Dimensions</b>	
P2060 Mounting flange.....	19
P2060 Side port.....	20
P2060 Thru-drive option.....	21
P2075 Mounting flange.....	22
P2075 Side port.....	23
P2075 Thru-drive option.....	24
P2105 Mounting flange.....	25
P2105 Side port.....	26
P2105 Thru-drive option.....	27
P2145 Mounting flange.....	28
P2145 Side port.....	29
P2145 Thru-drive option.....	30
P2 Shaft options.....	32
Torque control dimensions.....	32
<b>P3 Performance data</b>	
P3 Noise characteristics at max./min. displacement.....	33
P3 Series - typical drive power at full displacement.....	33
P3 Series - typical compensated input power.....	34
P3 Series - typical efficiency at full displ. at 1800 rpm.....	34
P3 Series - typical flow vs. pressure.....	35
P3 Series - typical compensated drain flow.....	35
P3 Series - typical inlet characteristics vs. speed at various percentage displacements.....	36
<b>P3 Dimensions</b>	
P3105 Mounting flange.....	37
P3105 Side port.....	38
P3105 Thru-drive option.....	39
P3145 Mounting flange.....	40
P3145 Side port.....	41
P3145 Thru-drive option.....	42
P3 Shaft options.....	44
Torque control dimensions.....	44
<b>General Installation Information</b> .....	45
Multiple pump combinations.....	45
Fluid recommendations, Seals.....	46

**Technical Features**

Variable displacement, axial piston pumps for open circuit hydraulic systems

Available as standard (P2) or supercharged (P3) version

Optimized for mobile applications:

- Dedicated envelope design and unique port layout
- High self-priming speed
- Standard integrated pre-compression volume
- Heavy duty approval (size 105 and 145) for increased power density

**Customer Benefits**

- Cost saving installation by direct PTO mount
- High productivity by maximized output flow
- High altitude operation capability
- Low noise level and reduced flow ripple

**P2 Series**



**P3 Series**



**Technical Data**

Frame size		P2 Series				P3 Series	
		P2060	P2075	P2105	P2145	P3105	P3145
Max. displacement	[cm <sup>3</sup> /rev]	60	75	105	145	105	145
Self-priming speed at 1 bar absolute inlet pressure <sup>1)</sup>	[rpm]	2800	2500	2300	2200	2600	2500
Nominal pressure <sup>2)</sup>	[bar]	320	320	350	350	350	350
Min. inlet pressure, absolute <sup>1)</sup>	[bar]	0.8	0.8	0.8	0.8	0.8	0.8
Max. inlet pressure, absolute	[bar]	10	10	10	10	1.5	1.5
Max. case drain pressure, absolute	[bar]	1.5	1.5	1.5	1.5	1.5	1.5
Min. outlet pressure, absolute	[bar]	15	15	15	15	15	15
Noise level at full flow at 1800 rpm and 250 bar	[dB(A)]	74	76	78	80	78	80
Weight with load sense control	[kg]	37	44	63	78	62	76
Mass moment of inertia (at axis of shaft)	[kg m <sup>2</sup> ]	0.0061	0.0101	0.0168	0.0241	0.0177	0.0264

1) Detailed inlet characteristics can be taken from page 18 and 36

2) For maximum operating pressures exceeding above mentioned nominal ratings please consult manufacturer

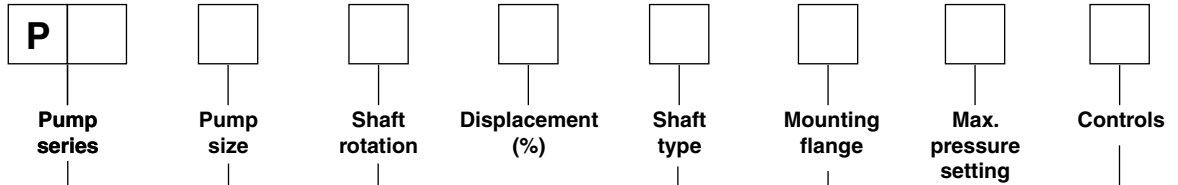

Code	Pump series
2	Standard
3	Super charged

Code	Pump size (max. displacement in cc/rev)	
	P2	P3
060	60	-
075	75	-
105	105	105
145	145	145

Code	Shaft rotation <sup>1)</sup>
R	Right (CW)
L	Left (CCW)

<sup>1)</sup> Viewed from shaft end.

Code	% of max. displacement
00	100 % stroke standard factory set
XX	Range is 70 % to 99 %

Code	Shaft type (splined) <sup>2) 3)</sup>	Pump size			
		060	075	105	145
B1	SAE B	•	-	-	-
B2	SAE B-B	•	•	-	-
C1	SAE C	•	•	•	•
C2	SAE C-C	-	•	•	•
C3	SAE C, w/o undercut	•	•	•	•
D1	SAE D	-	-	•	•
D2	SAE D, w/o undercut	-	-	•	•
M6	DIN 5480, W50	-	-	-	•

<sup>2)</sup> See pages 32 and 44 for permissible input torque.

<sup>3)</sup> For further shaft options please consult manufacturer.

Code	Mounting flange	Pump size			
		060	075	105	145
B	SAE B 2-bolt	•	-	-	-
C	SAE C 2-bolt	-	-	-	•
	SAE C 2 & 4-bolt	-	•	•	-
D	SAE C 4-bolt	•	-	-	<sup>4)</sup>
	SAE D 4-bolt	-	-	-	•

<sup>4)</sup> Please consult manufacturer.

Code	Max. pressure setting	
XX	Pressure setting in 10 bar increments	
	060	100 to 320 bar, XX = [10...32]
	075	
	105	100 to 350 bar, XX = [10...35]
145		

Code	Controls
PA	Max. pressure control
RA	Remote pressure control with max. pressure control
LA	Load sensing control w/o bleed-off orifice, with max. pressure control
LB	Load sensing control with bleed-off orifice, with max. pressure control
TA	Torque control, load sensing w/o bleed-off orifice and max. pressure control, range 20...60 % of reference torque value
TB	Torque control, load sensing with bleed-off orifice and max. pressure control, range 20...60% of reference torque value
TC	Torque control, load sensing w/o bleed-off orifice and max. pressure control, range 50...90 % of reference torque value
TD	Torque control, load sensing with bleed-off orifice and max. pressure control, range 50...90 % of reference torque value

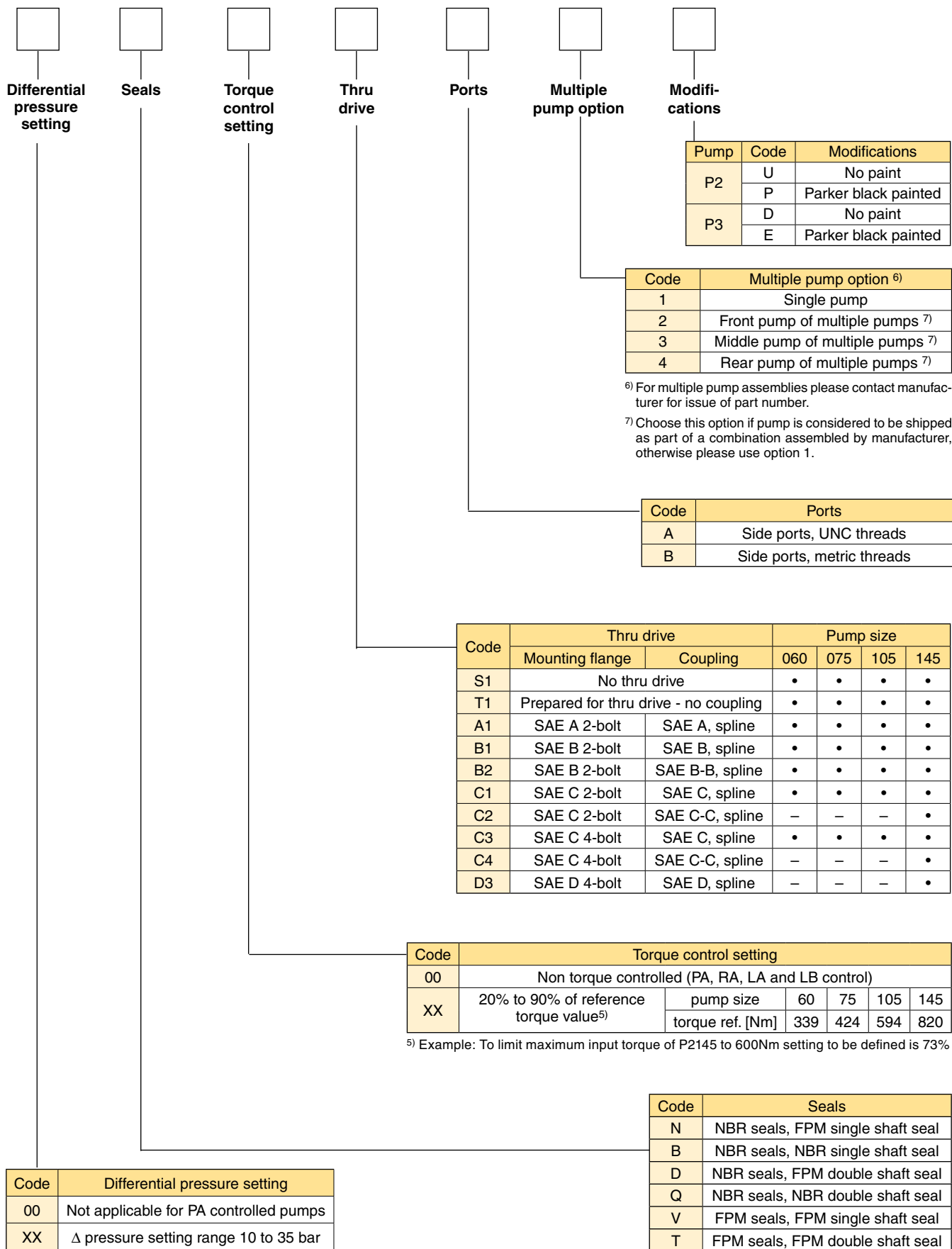

**Pressure control**

The pressure control is used to limit the maximum system pressure. The control acts such that full pump displacement is achieved unless the load pressure reaches the maximum setting of the control. If pump flow is restricted by the system valve, the pump will provide only the flow demanded, but at the maximum pressure setting of the compensator control. If the outlet flow is completely blocked, the pump will de-stroke to zero displacement and maintain the pressure at the setting of the compensator spring.

Response times of the pump are collected from a circuit as below by measuring the pumps swash angle movement at different pressures.

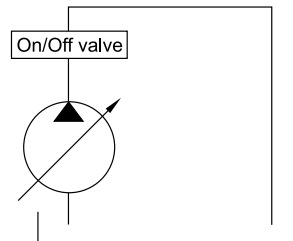

**P2 Control schematics**

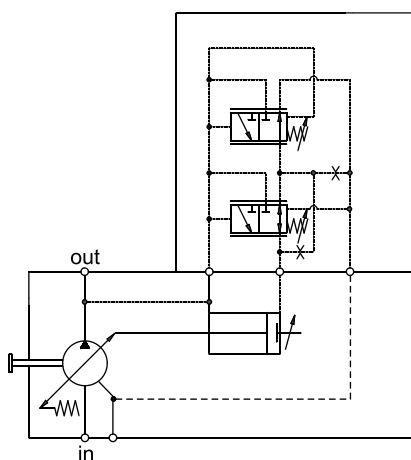

**Dynamic characteristic of flow control \***

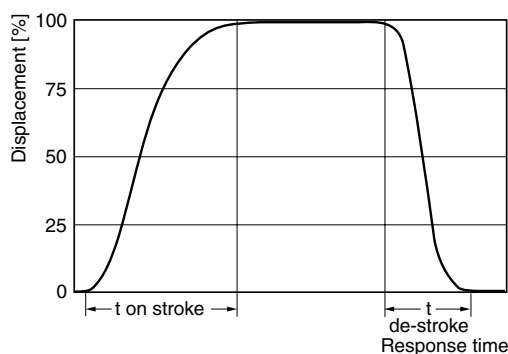

**P3 Control schematics**

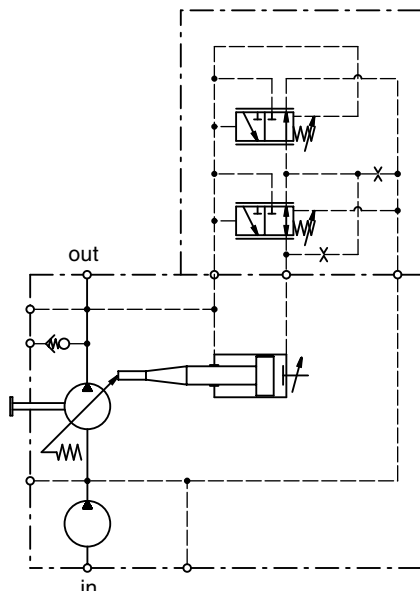

	t on stroke [ms]		t de-stroke [ms]
	against 50 bar	against 220 bar	zero stroke 280 bar
P2060	70	65	30
P2075	70	70	30
P2105 / P3105	120	90	30
P2145 / P3145	160	130	30

Compensator oil consumption PA control	max. 3.0 l/min
Pressure compensator adjusting range	Size 105 and 145 100 ... 350 bar
	Size 60 and 75 100 ... 320 bar
Hysteresis and repetitive accuracy	max. 3 bar

\* Curve shown exaggerated

**Remote pressure control**

This control allows the pump pressure compensator setting to be adjusted from a remote relief valve. The control acts such that when full pump displacement is achieved the load pressure reaches the maximum setting of the remote relief valve. If pump flow is restricted by the system valve, the pump will provide only the flow demanded, but at the maximum pressure setting of the compensator control. If the outlet flow is completely blocked, the pump will de-stroke to zero displacement and maintain the pressure at the setting of the remote relief valve.

Response times of the pump are collected from a circuit as below by measuring the pumps swash angle movement at different pressures.

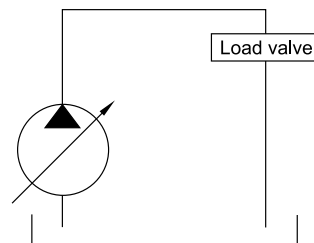

**P2 Control schematics**

X port (connect remote relief valve here)

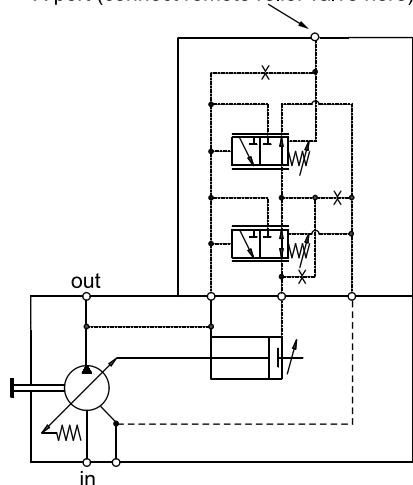

**Dynamic characteristic of flow control \***

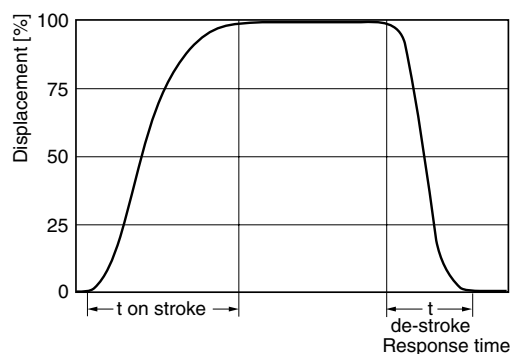

**P3 Control schematics**

X port (connect remote relief valve here)

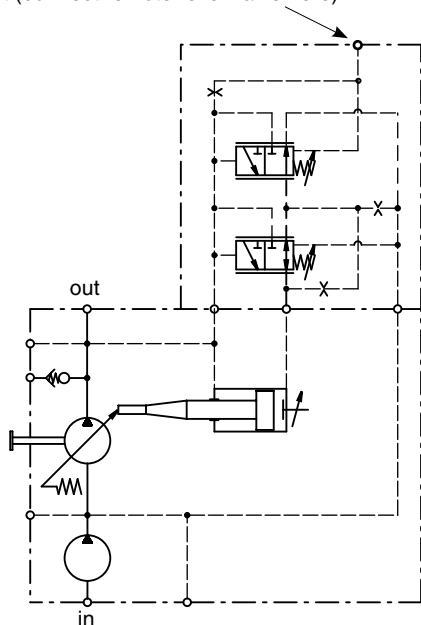

	t on stroke [ms]		t de-stroke [ms]	
	stand by to 250 bar	250 bar to stand by	50 bar to stand by	stand by
P2060	60	30	40	
P2075	80	35	40	
P2105 / P3105	100	40	45	
P2145 / P3145	120	45	50	

Compensator oil consumption 'RA control	max. 3.0 l/min
Pilot pressure valve oil consumption	max. 2.0 l/min
Delta P compensator adjusting range	10 ... 35 bar
Pressure compensator adjusting range	Size 105 and 145 100 ... 350 bar
	Size 60 and 75 100 ... 320 bar
Hysteresis and repetitive accuracy	max. 3 bar

\* Curve shown exaggerated

**Load sensing control with maximum pressure control**

These controls feature load sensing and maximum pressure compensation. Load sense controls are used to match pump flow to system demands.

Response times of the pump are collected from a circuit as below by measuring the pumps swash angle movement at different pressures.

**P2 Control schematics**

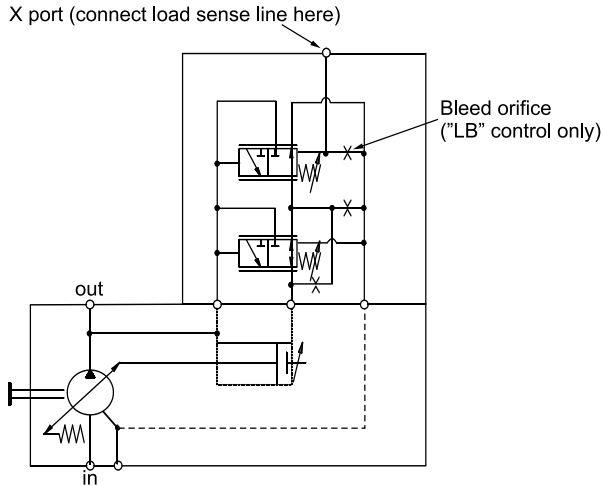

**P3 Control schematics**

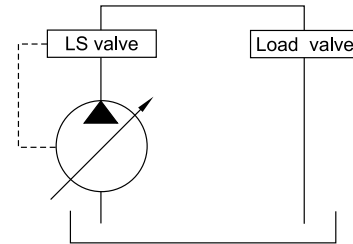
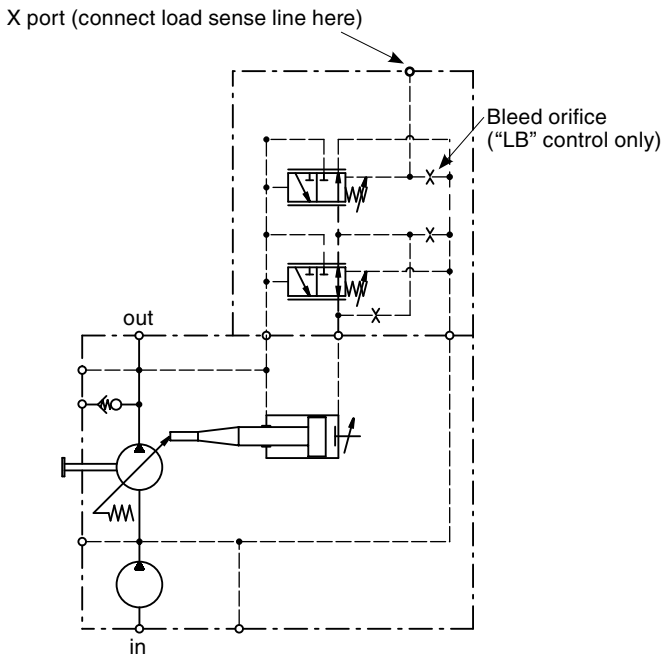

**Dynamic characteristic of flow control \***

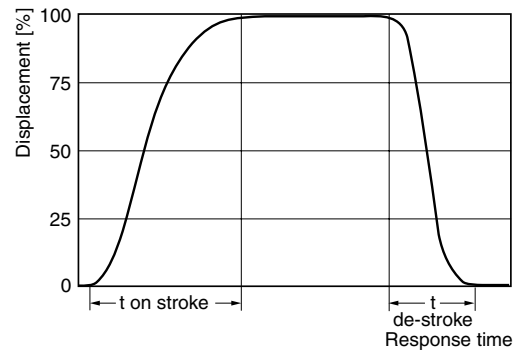

	t on stroke [ms]		t de-stroke [ms]	
	stand by to 250 bar	250 bar to stand by	250 bar to 50 bar	50 bar to stand by
P2060	60	30	40	40
P2075	80	35	40	40
P2105 / P3105	100	40	45	45
P2145 / P3145	120	45	50	50

Compensator oil consumption LA control	max. 3.0 l/min
Compensator oil consumption LB control	max. 4.5 l/min
Load sensing compensator adjusting range	10 ... 35 bar
Pressure compensator adjusting range	Size 105 and 145 100 ... 350 bar
	Size 60 and 75 100 ... 320 bar
Hysteresis and repetitive accuracy	max. 3 bar

\* Curve shown exaggerated

**Differential setting vs. stand-by pressure**

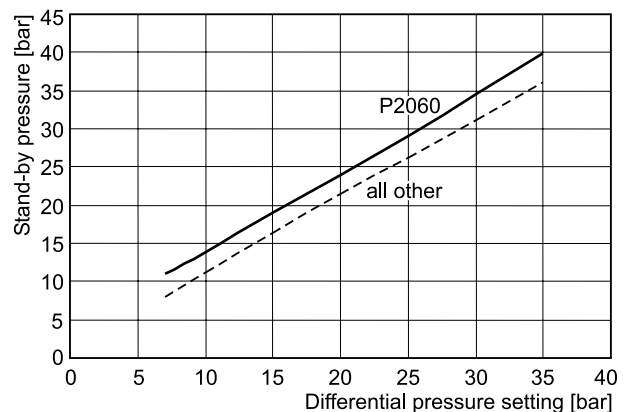



**Torque limiting control with load sensing and maximum pressure control limiter**

These controls provide the benefits of the load sensing and pressure limiting controls, plus the ability to limit the input torque the pump will draw. These controls are beneficial when the power available from the prime mover for the hydraulics is limited or the application power demand has both high flow/low pressure and low flow/high pressure duty cycles.

**P2 Control schematics**

X port (connect load sense line here)

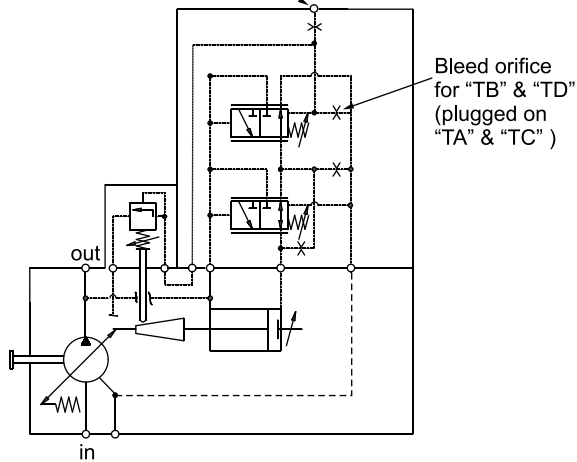

**P3 Control schematics**

X port (connect load sense line here)

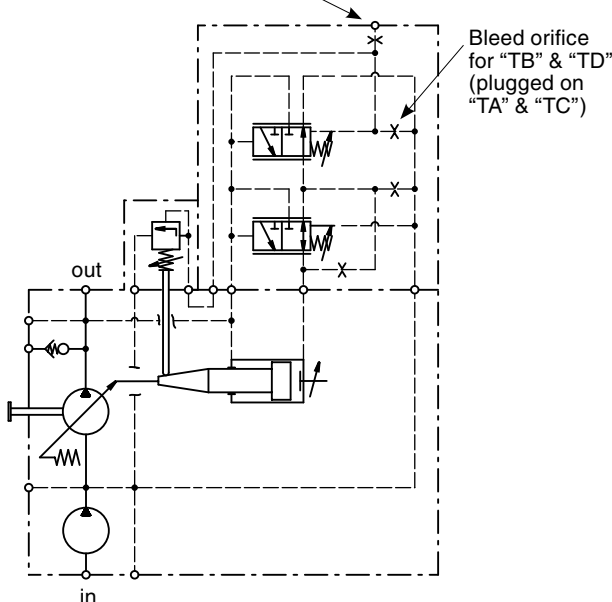

Response times of the pump are collected from a circuit as below by measuring the pumps swash angle movement at different pressures.

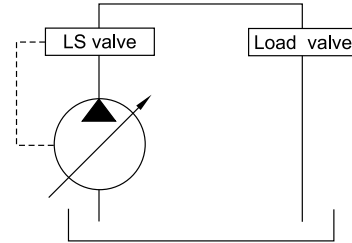

**Dynamic characteristic of flow control \***

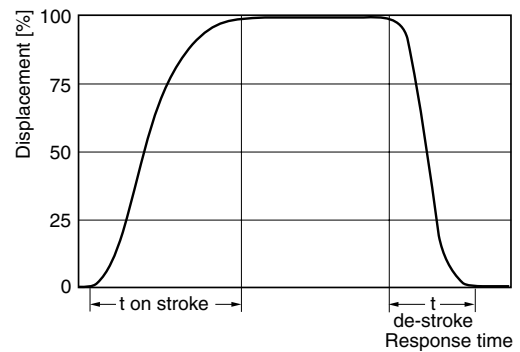

	t on stroke [ms]		t de-stroke [ms]	
	stand by to 250 bar	250 bar to stand by	50 bar to stand by	stand by
P2060	60	30	40	
P2075	80	35	40	
P2105 / P3105	100	40	45	
P2145 / P3145	120	45	50	

Compensator oil consumption TA, TC control	max. 3.0 l/min
Compensator oil consumption TB, TD control	max. 4.5 l/min
Torque control valve oil consumption	max. 2.0 l/min
Load sensing compensator adjusting range	10 ... 35 bar
Pressure compensator adjusting range	Size 105 and 145 100 ... 350 bar
	Size 60 and 75 100 ... 320 bar
Hysteresis and repetitive accuracy	max. 3 bar

\* Curve shown exaggerated

**P2060 - 20...60 % Torque (1800 rpm)**

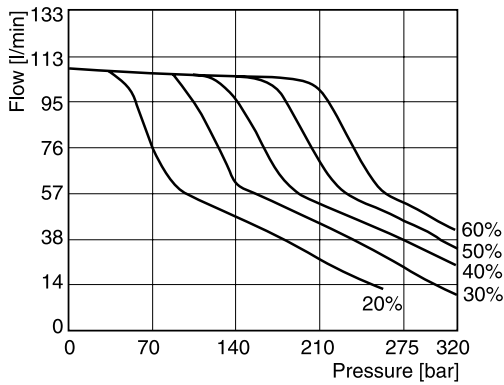

**P2060 - 50...90 % Torque (1800 rpm)**

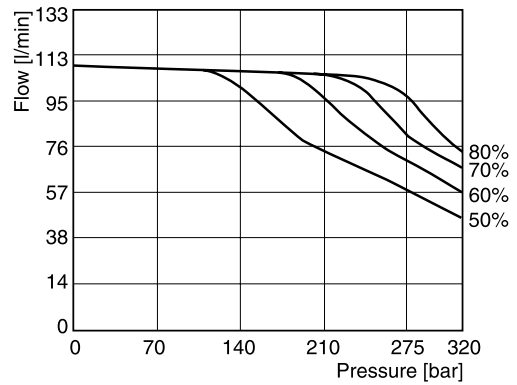

**P2075 - 20...60 % Torque (1800 rpm)**

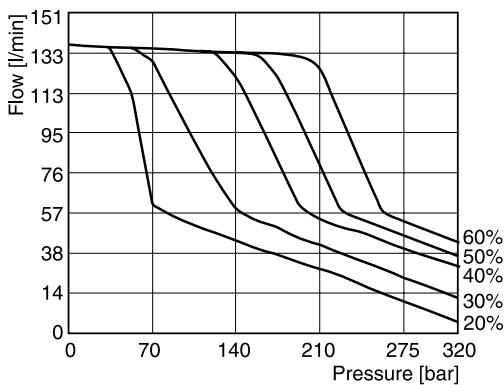

**P2075 - 50...90 % Torque (1800 rpm)**

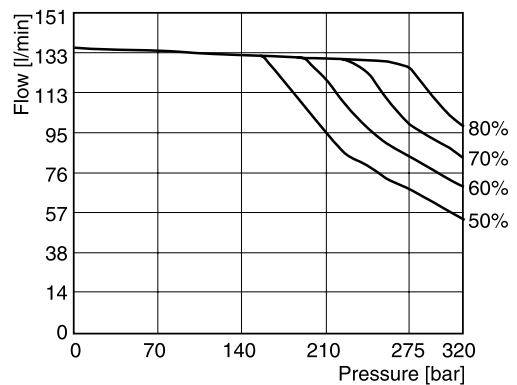

**P2105 - 20...60 % Torque (1800 rpm)**

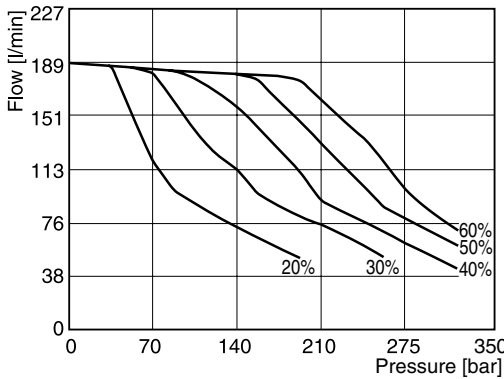

**P2105 - 50...90 % Torque (1800 rpm)**

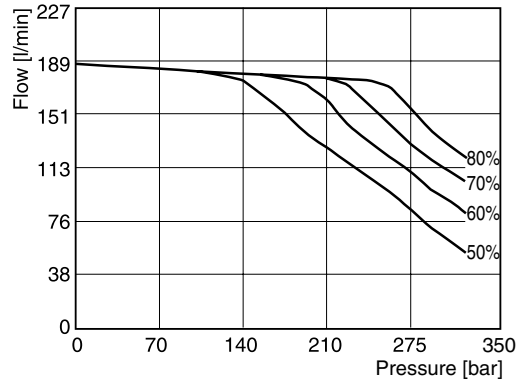

**P2145 - 20...60 % Torque (1800 rpm)**

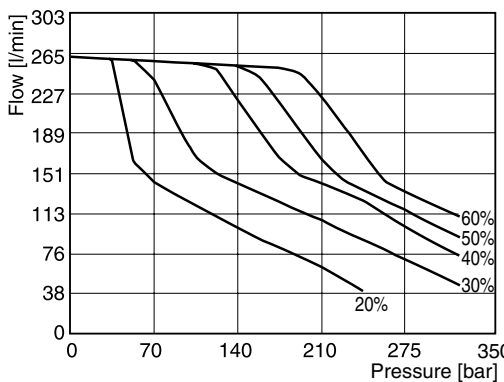

**P2145 - 50...90 % Torque (1800 rpm)**

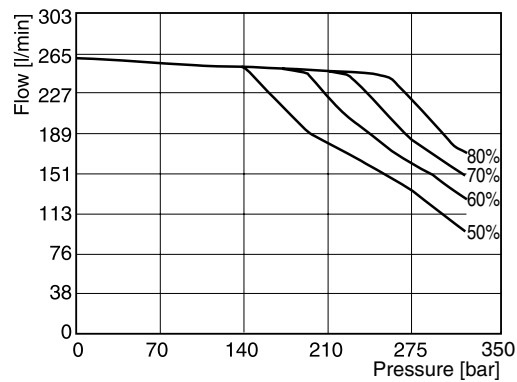

Fluid: Mineral oil ISO VG 32 at 40°C ; Inlet pressure: 1.0 bar (absolute) measured at inlet port.

**P3105 - 20...60 % Torque (1800 rpm)**

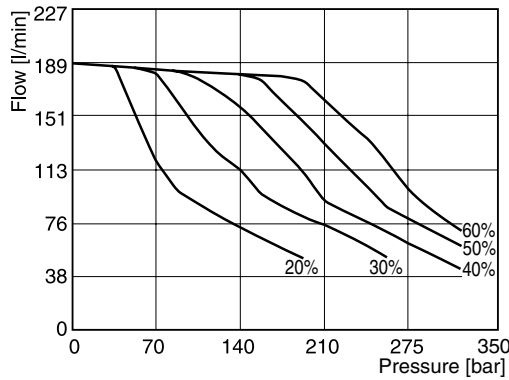

**P3105 - 50...90 % Torque (1800 rpm)**

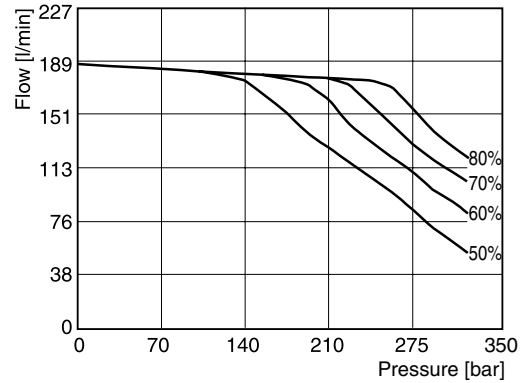

**P3145 - 20...60 % Torque (1800 rpm)**

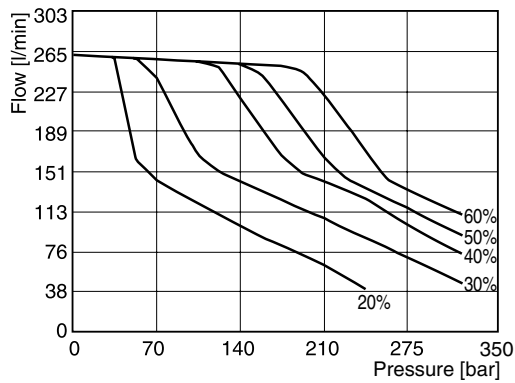

**P3145 - 50...90 % Torque (1800 rpm)**

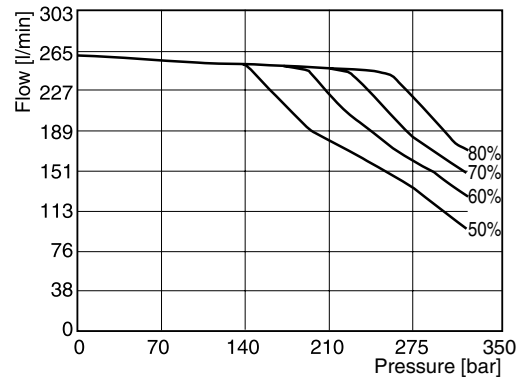

Fluid: Mineral oil ISO VG 32 at 40°C ; Inlet pressure: 1.0 bar (absolute) measured at inlet port.

**Ripple chamber**

**Pressure ripple at 200 bar**

The chart on the right refers to the “Ripple Chamber” technology engineered into the P2 and P3 series pumps. The ripple chamber reduces flow pulsation and due to this pressure pulsation (called “ripple”) at the outlet of the pump. This technology reduces the ripple by 40–60%. This leads to a significant reduction in overall system noise without additional components or cost.

**The ripple chamber is standard on all P2 and P3 series side ported pumps.**

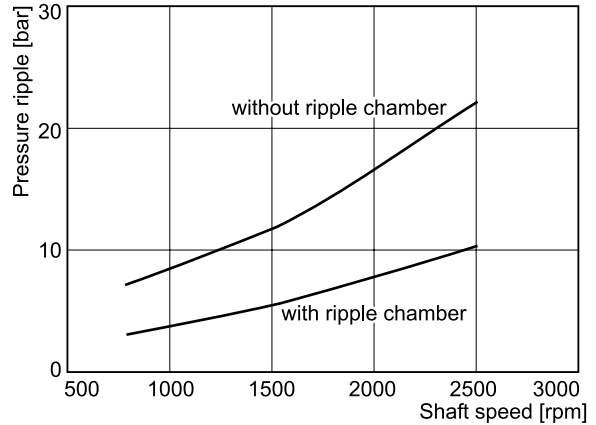

**P2 Noise characteristics at max./min. displacement**

**P2060 Noise characteristics**

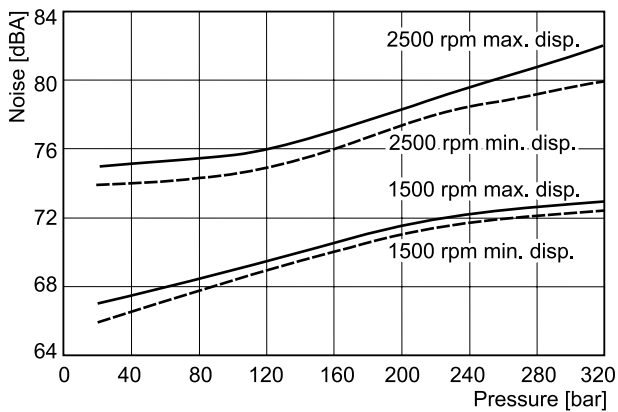

**P2075 Noise characteristics**

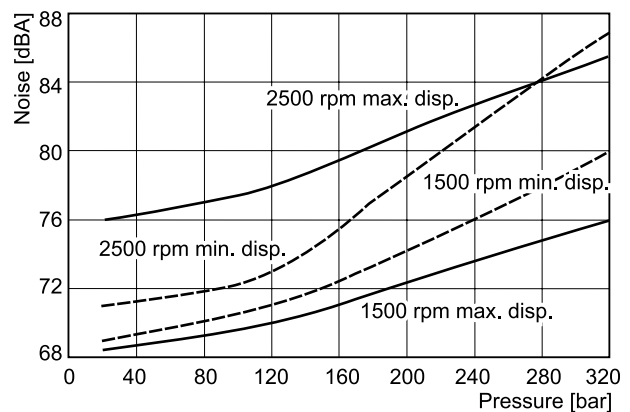

**P2105 Noise characteristics**

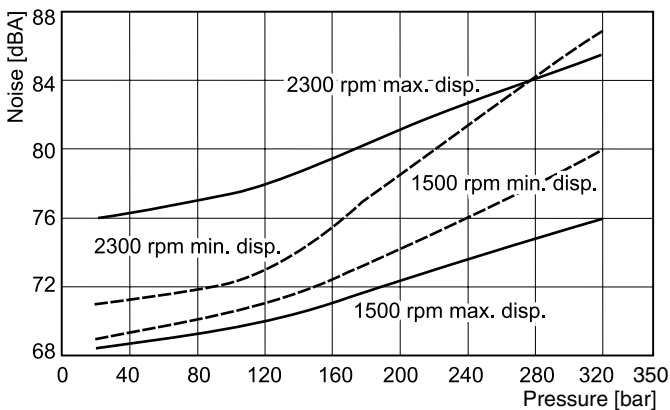

**P2145 Noise characteristics**

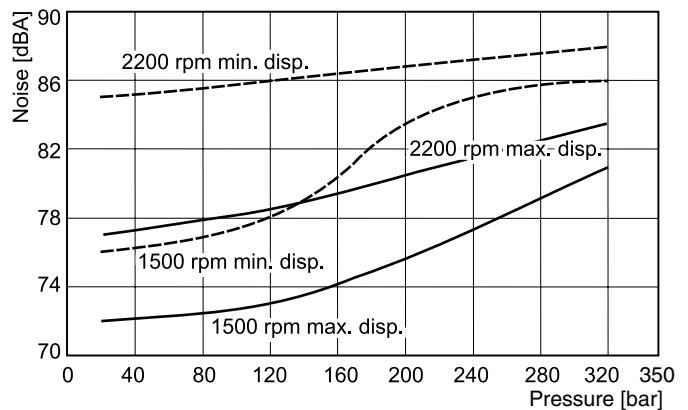

**P2 Series - typical drive power at full displacement  
 P2060 Input power - full stroke**

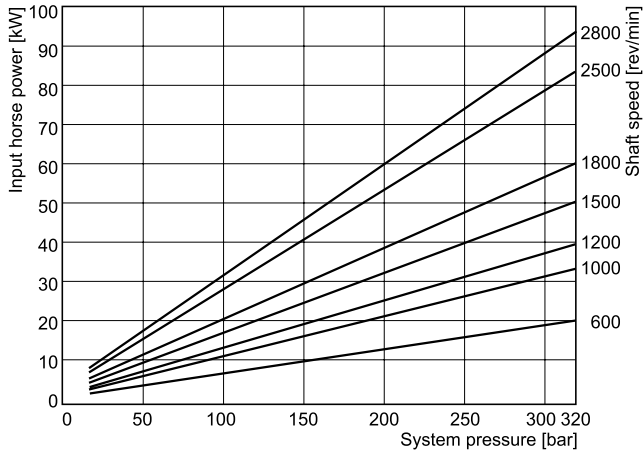

**P2075 Input power - full stroke**

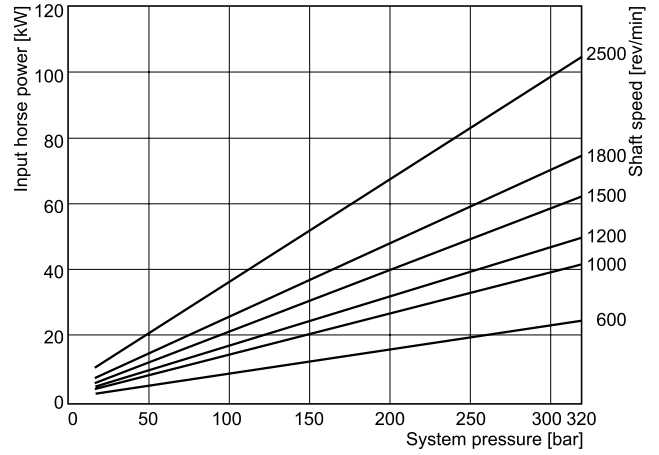

**P2105 Input power - full stroke**

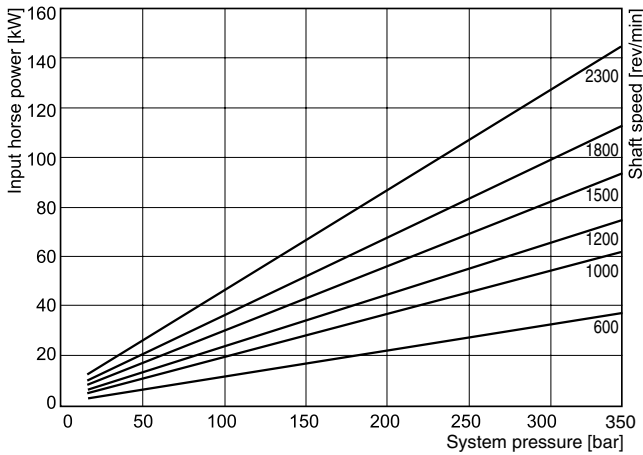

**P2145 Input power - full stroke**

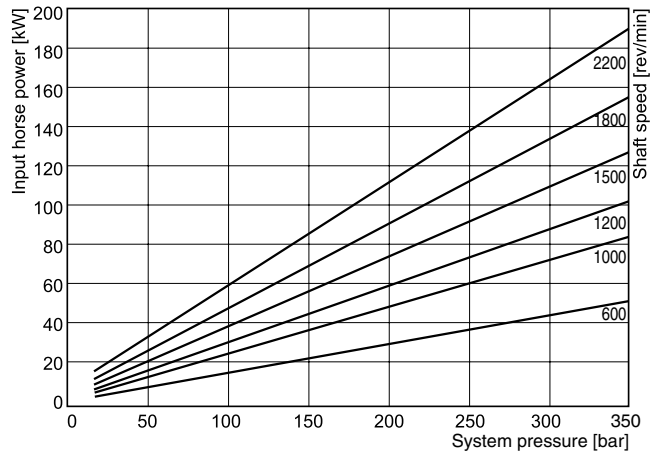

Fluid: Mineral oil ISO VG 32 at 40°C ; Inlet pressure: 1.0 bar (absolute) measured at inlet port.

**P2 Series - typical compensated input power  
 P2060 Input power - zero stroke**

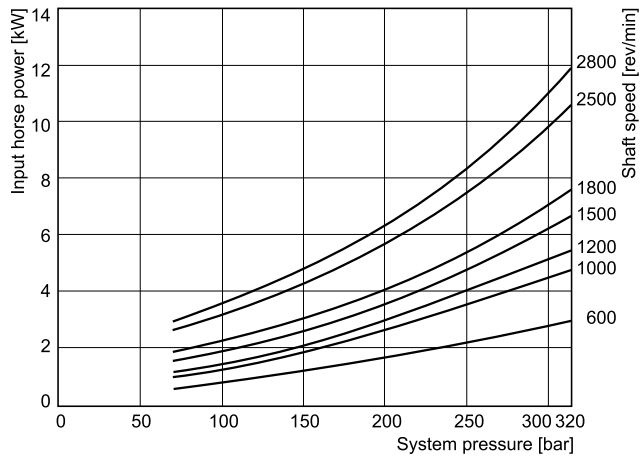

**P2075 Input power - zero stroke**

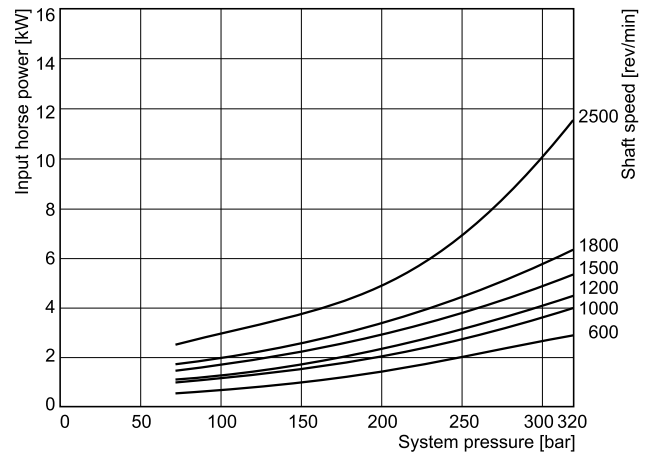

**P2105 Input power - zero stroke**

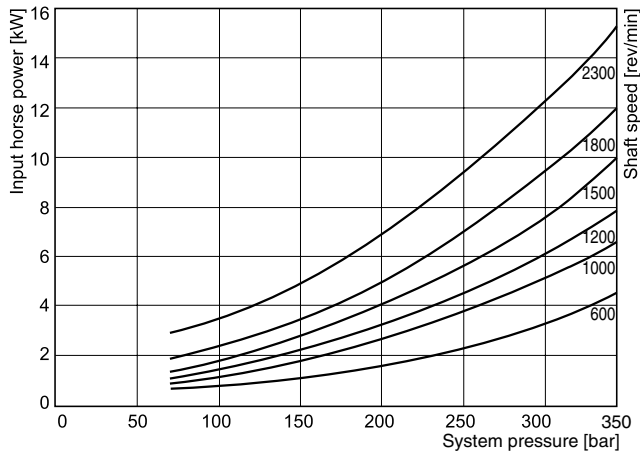

**P2145 Input power - zero stroke**

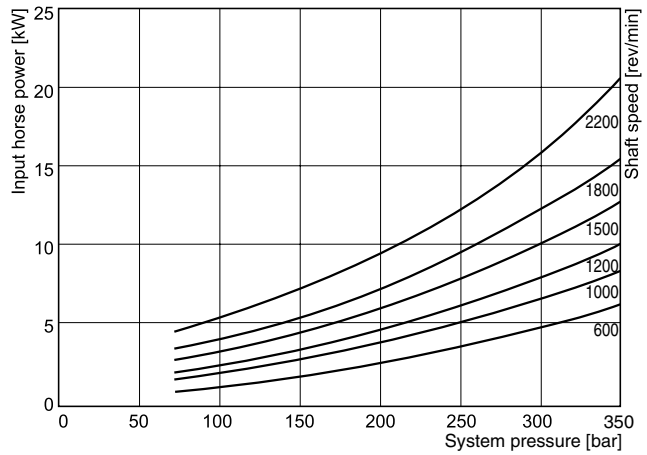

Fluid: Mineral oil ISO VG 32 at 40°C ; Inlet pressure: 1.0 bar (absolute) measured at inlet port.

**P2 Series - typical efficiency at full displacement at 1800 rpm**

**P2060 Efficiency at 1800 rpm**

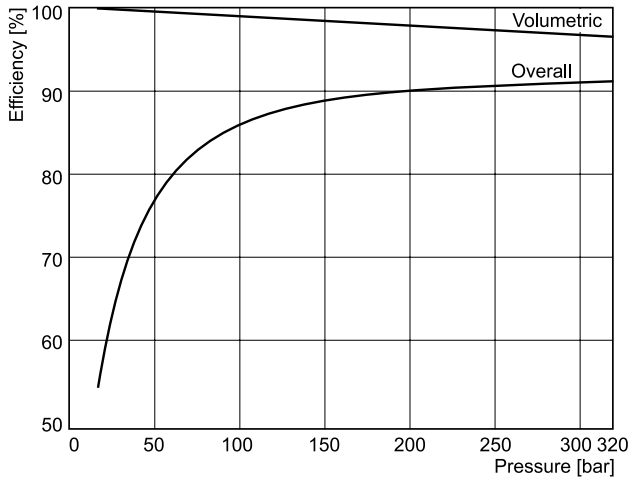

**P2075 Efficiency at 1800 rpm**

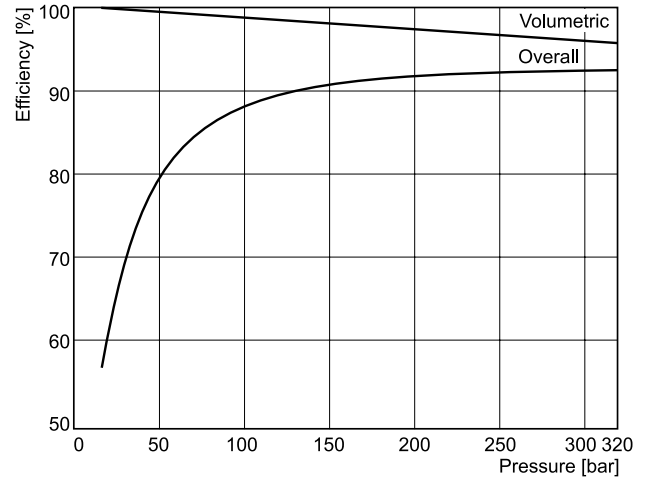

**P2105 Efficiency at 1800 rpm**

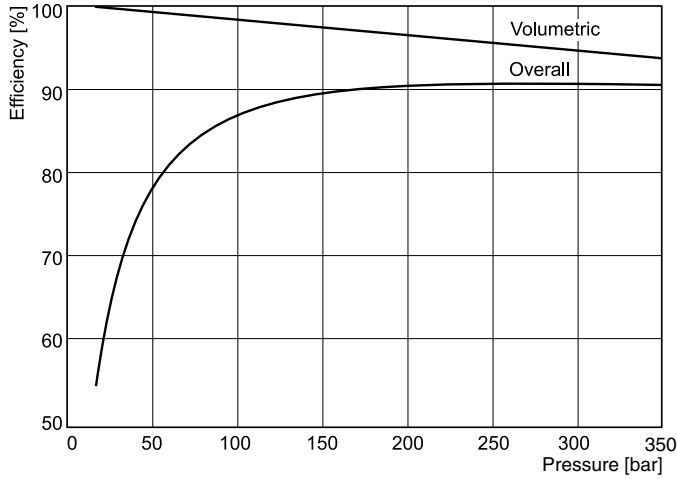

**P2145 Efficiency at 1800 rpm**

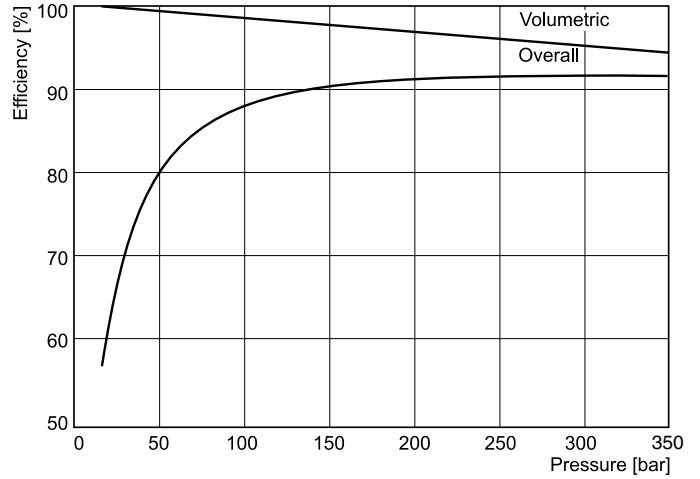

Fluid: Mineral oil ISO VG 32 at 40°C ; Inlet pressure: 1.0 bar (absolute) measured at inlet port.

**P2 Series - typical flow vs. pressure**

**P2060 Outlet flow - full stroke**

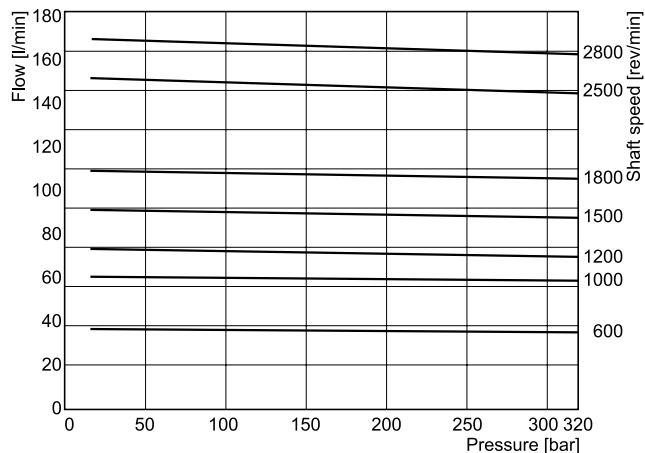

**P2075 Outlet flow - full stroke**

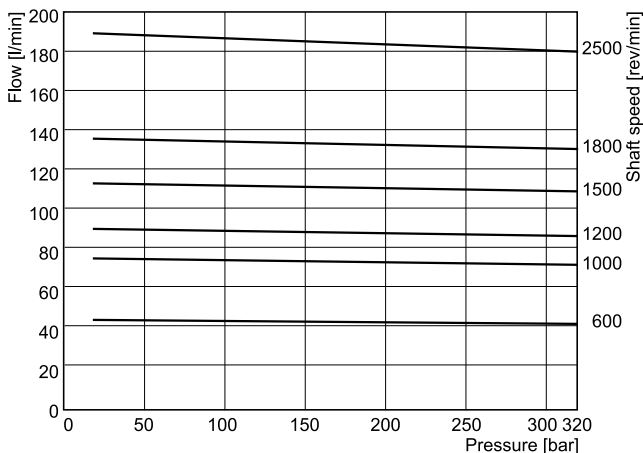

**P2105 Outlet flow - full stroke**

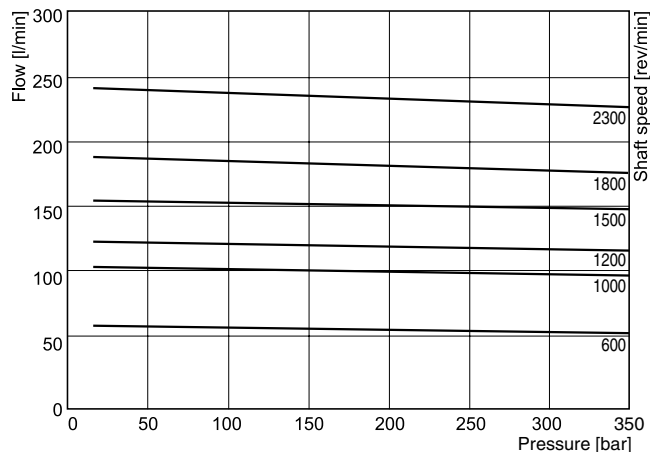

**P2145 Outlet flow - full stroke**

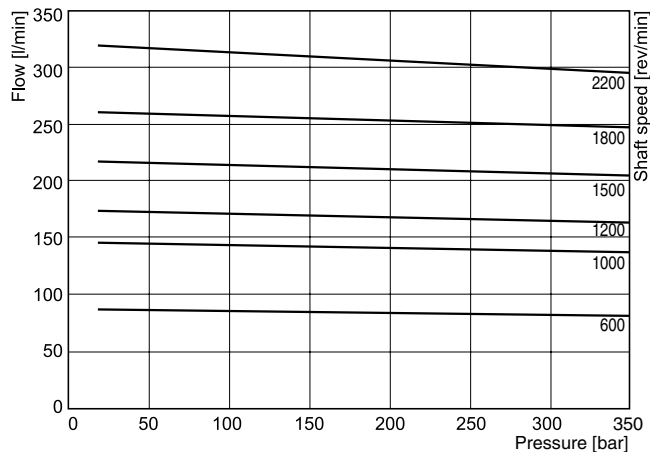

Fluid: Mineral oil ISO VG 32 at 40°C ; Inlet pressure: 1.0 bar (absolute) measured at inlet port.



**P2 Series - typical compensated case drain flow  
 P2060 Drain flow at zero stroke**

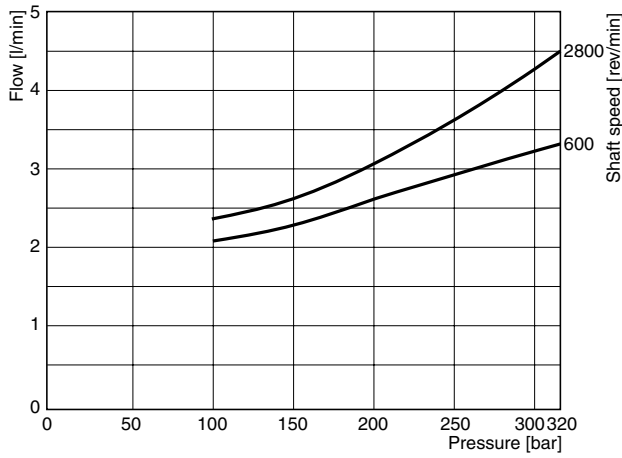

**P2075 Drain flow at zero stroke**

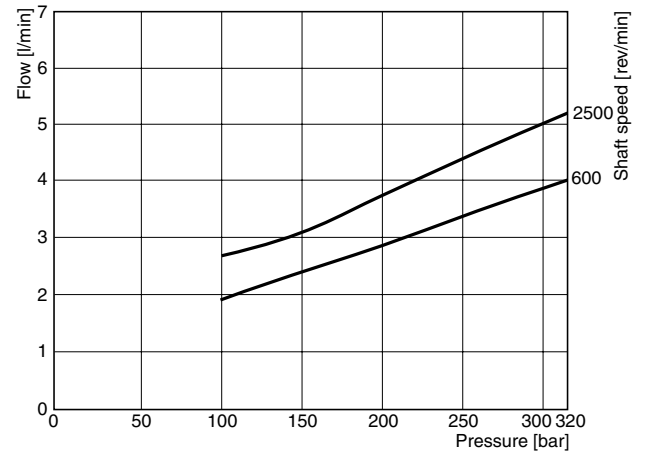

**P2105 Drain flow at zero stroke**

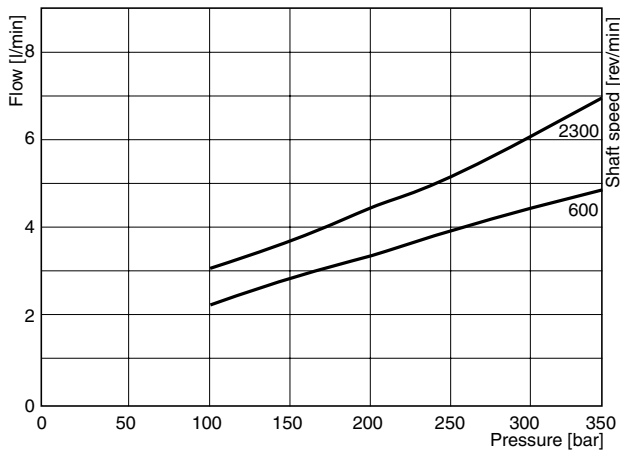

**P2145 Drain flow at zero stroke**

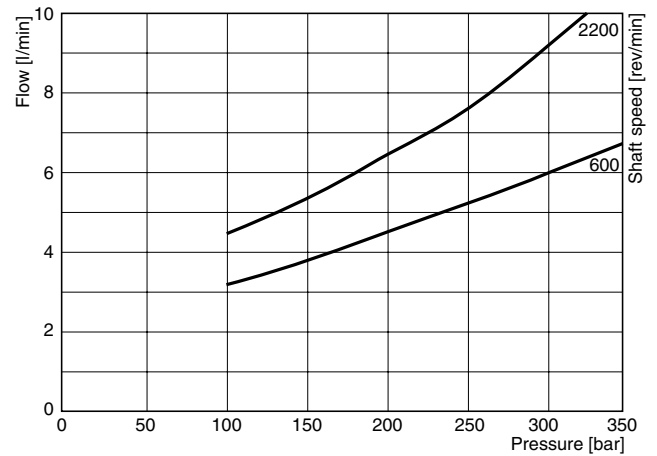

Fluid: Mineral oil ISO VG 32 at 40°C ; Inlet pressure: 1.0 bar (absolute) measured at inlet port.

**P2 Series - typical inlet characteristics vs. speed at various percentage displacements**

**P2060 Inlet characteristics**

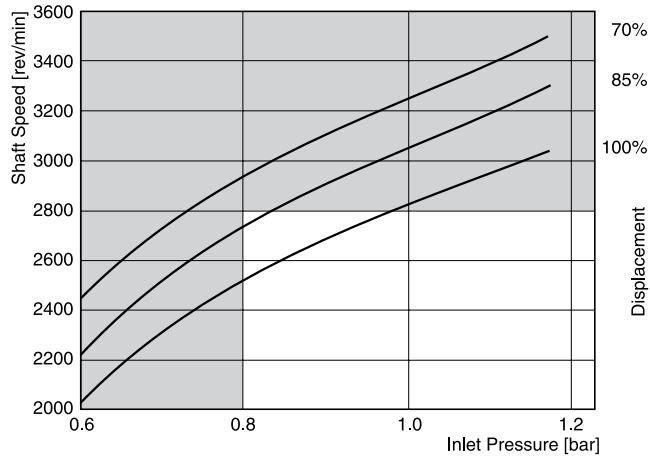

**P2075 Inlet characteristics**

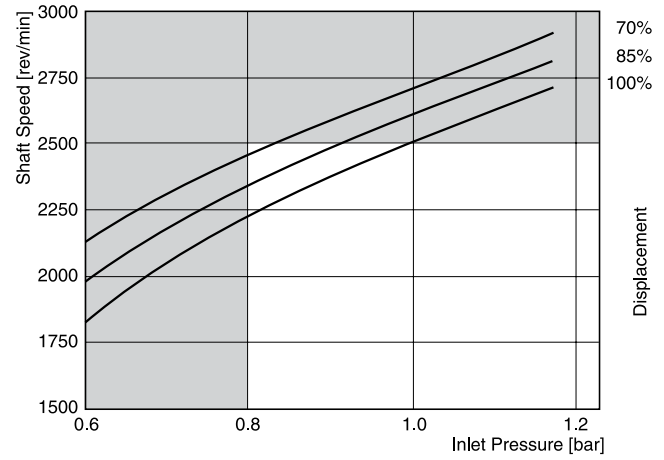

**P2105 Inlet characteristics**

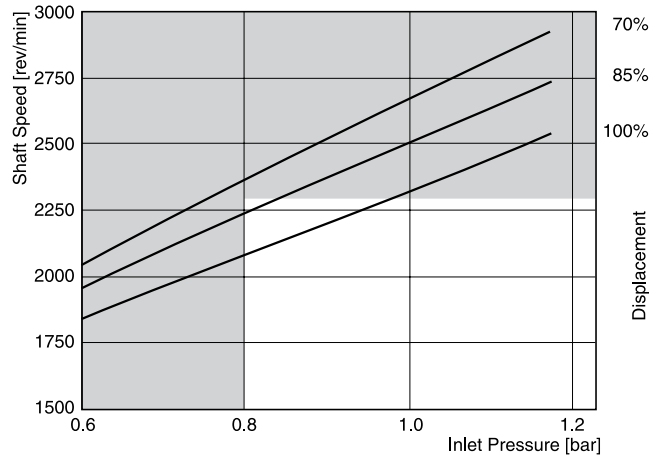

**P2145 Inlet characteristics**

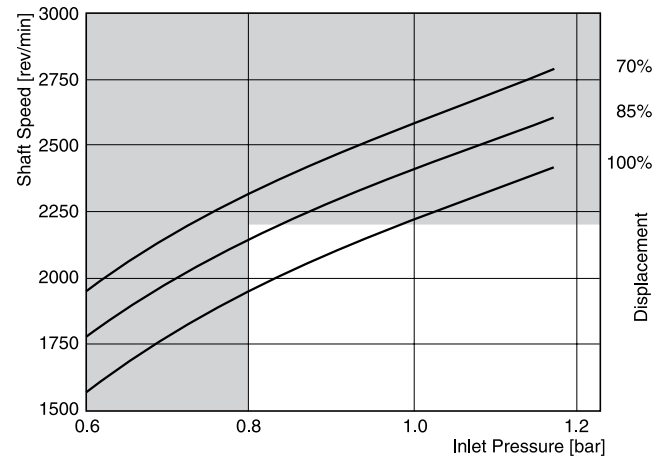

Fluid: Mineral oil ISO VG 32 at 40°C ; Inlet pressure: 1.0 bar (absolute) measured at inlet port.

For operation at these conditions, please consult manufacturer for approval.

**Dimensions**

**Axial Piston Pumps  
Series P2**

**P2060 Mounting flange**

**SAE B 2-bolt mounting flange**

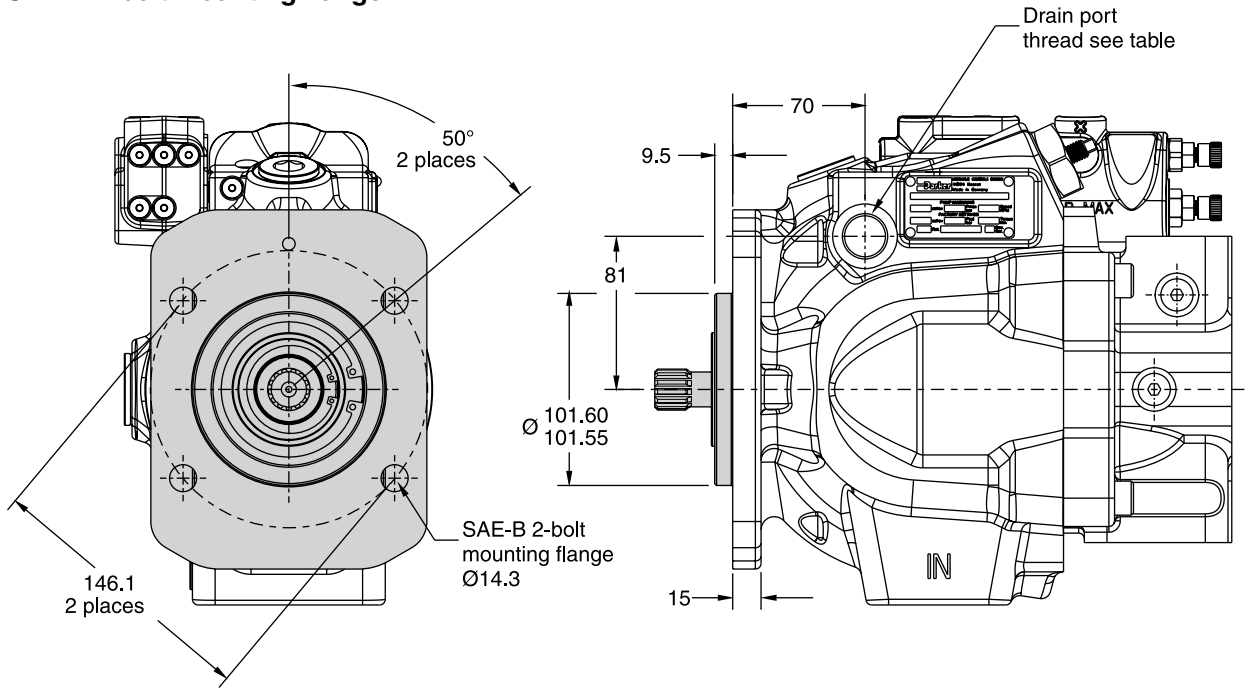

**SAE C 4-bolt mounting flange**

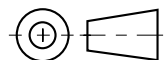
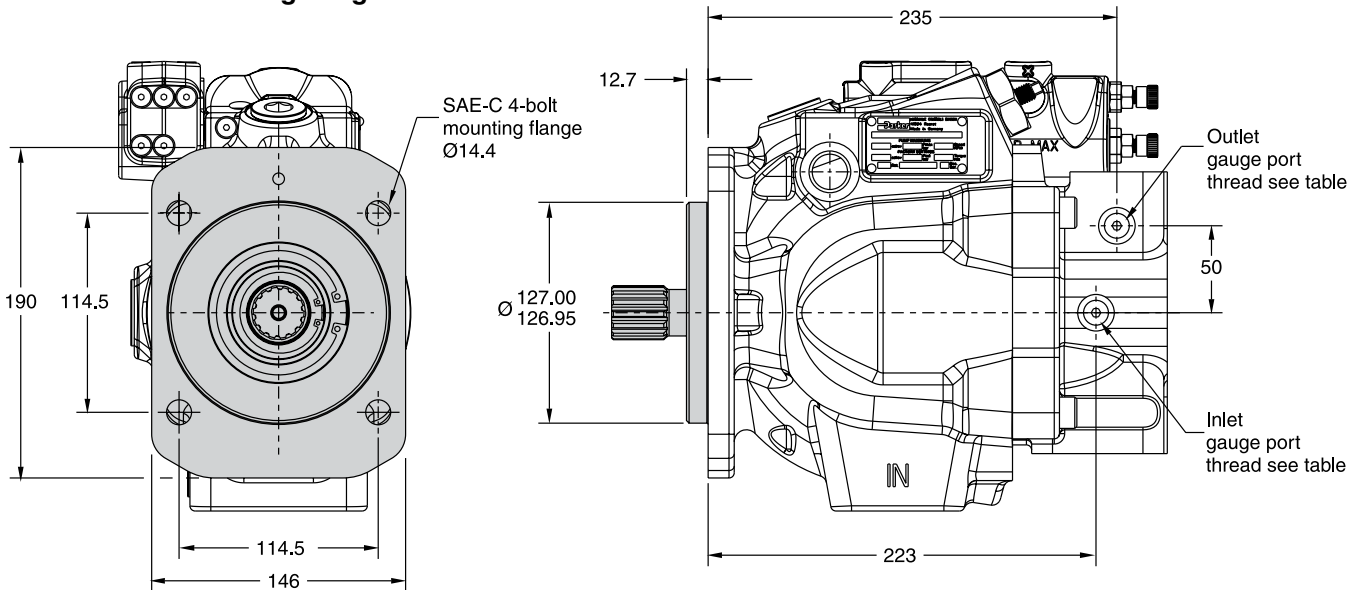

CW pump shown.  
CCW pump will have inlet and outlet gauge ports reversed.

Port ordering code	Drain port	Inlet gauge port / Outlet gauge port / Signal port
"A" side - UNC	SAE-10 straight thread / O-ring port: 7/8-14 UN thread	SAE-4 straight thread / O-ring port: 7/16-20 UN thread
"B" side - metric	ISO 6149 straight thread / O-ring port: M22 x 1.5 thread	ISO 6149 straight thread / O-ring port: M12 x 1.5 thread

**P2060 Side port**

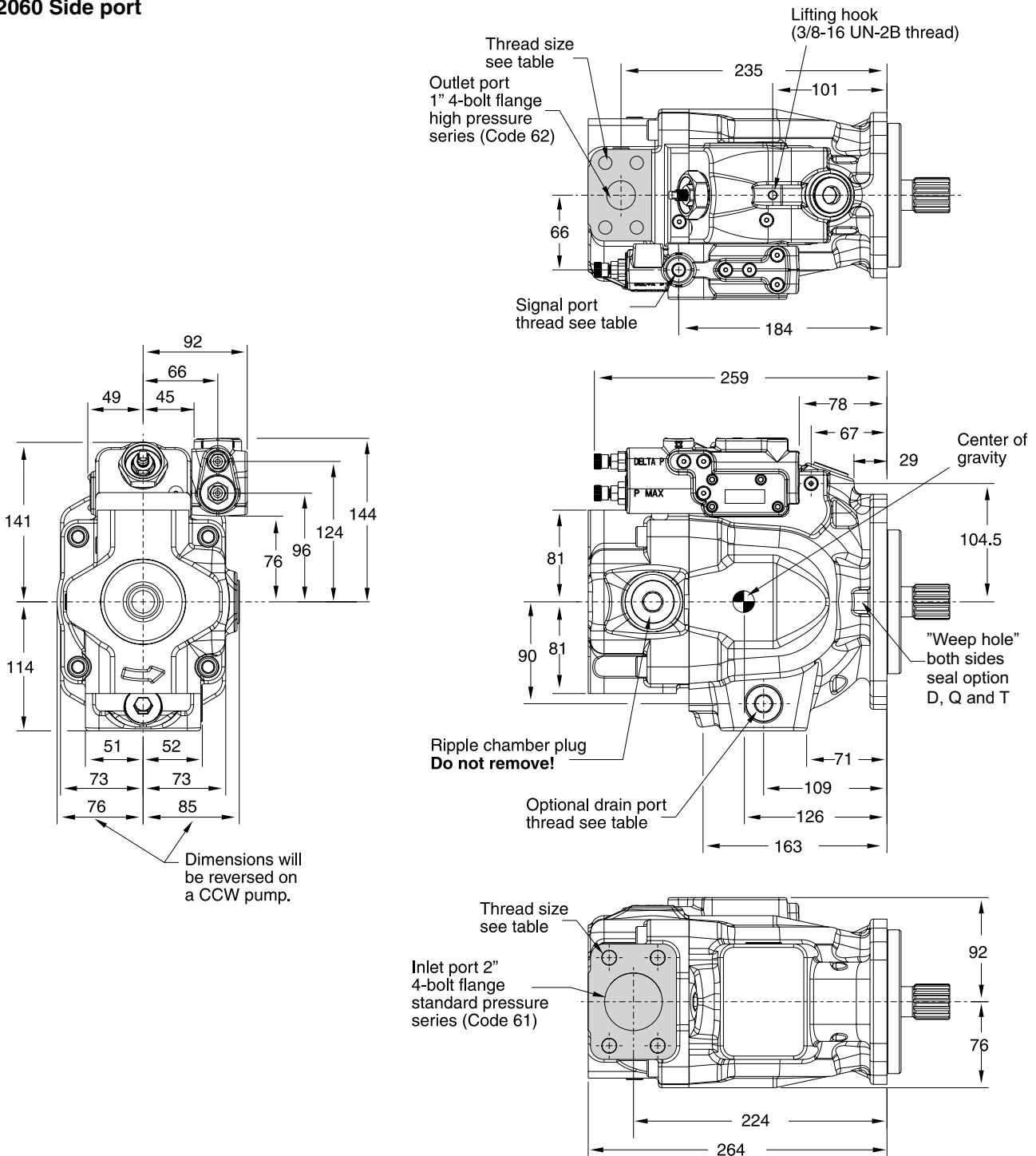

Pump shown is a CW rotation P2060 series pump with load sense and max. pressure compensator.

**As an option the compensator unit can be positioned at opposite side of the pump. Please consult manufacturer for details.**

CCW pump will have inlet and outlet gauge ports reversed.

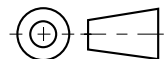

Port option	Drain port	Inlet port	Outlet port	Inlet gauge port / Outlet gauge port / Signal port
"A" side - UNC	SAE-10 straight thread / O-ring port: 7/8-14 UN thread	1/2-13 UN	7/16-14 UN	SAE-4 straight thread / O-ring port: 7/16-20 UN thread
"B" side - metric	ISO 6149 straight thread / O-ring port: M22 x 1.5 thread	M12 x 1.75	M12 x 1.75	ISO 6149 straight thread / O-ring port: M12 x 1.5 thread

**P2060 Thru-drive option**

**A1 configuration**

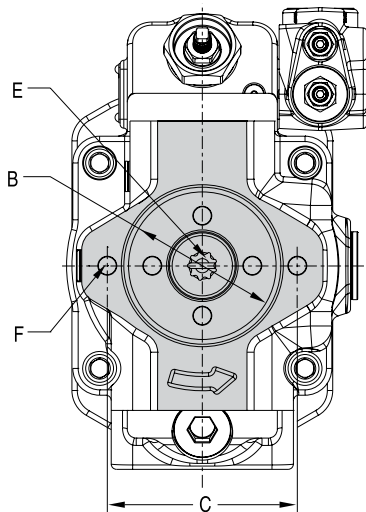

**B1 and B2 configurations**

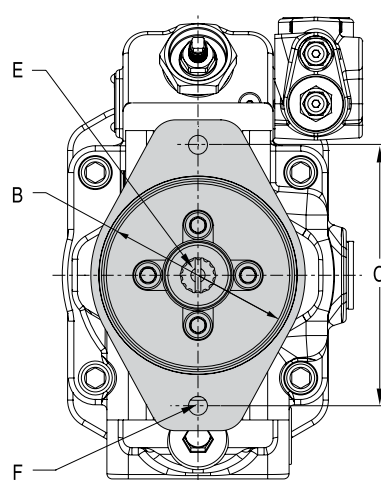

**C1 and C3 configurations**

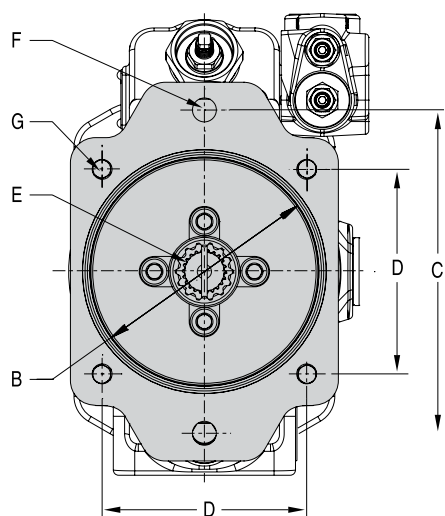

**P2060 partial cut-away of thru-drive area**

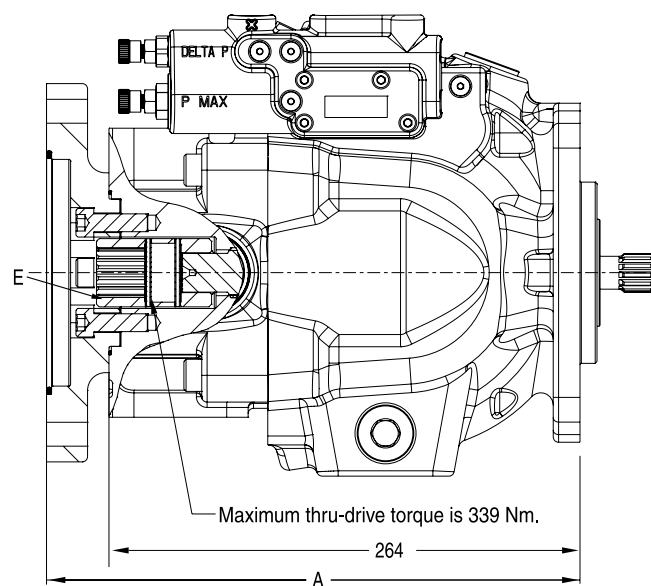

Thru-shaft option	A	B Ø	C	D	E	F UNC	F metric	G UNC	G metric	Weight
<b>A1</b>	264	82.625 82.575	106.38	N/A	SAE-A spline 9 tooth 16/32 pitch	3/8-16 UNC-2B THD	M10 x 1.5 THD	N/A	N/A	36.2 kg
<b>B1</b>	297	101.676 101.625	146.05	N/A	SAE-B spline 13 tooth 16/32 pitch	1/2-13 UNC-2B THD	M12 x 1.75 THD	N/A	N/A	38.9 kg
<b>B2</b>	297	101.676 101.625	146.05	N/A	SAE-BB spline 15 tooth 16/32 pitch	1/2-13 UNC-2B THD	M12 x 1.75 THD	N/A	N/A	38.9 kg
<b>C1 C3</b>	299	127.076 127.025	180.98	114.5	SAE-C spline 14 tooth 12/24 pitch	5/8-11 UNC-2B THD	M16 x 2 THD	1/2-13 UNC-2B THD	M12 x 1.75 THD	40.2 kg

**P2075 Mounting flange**

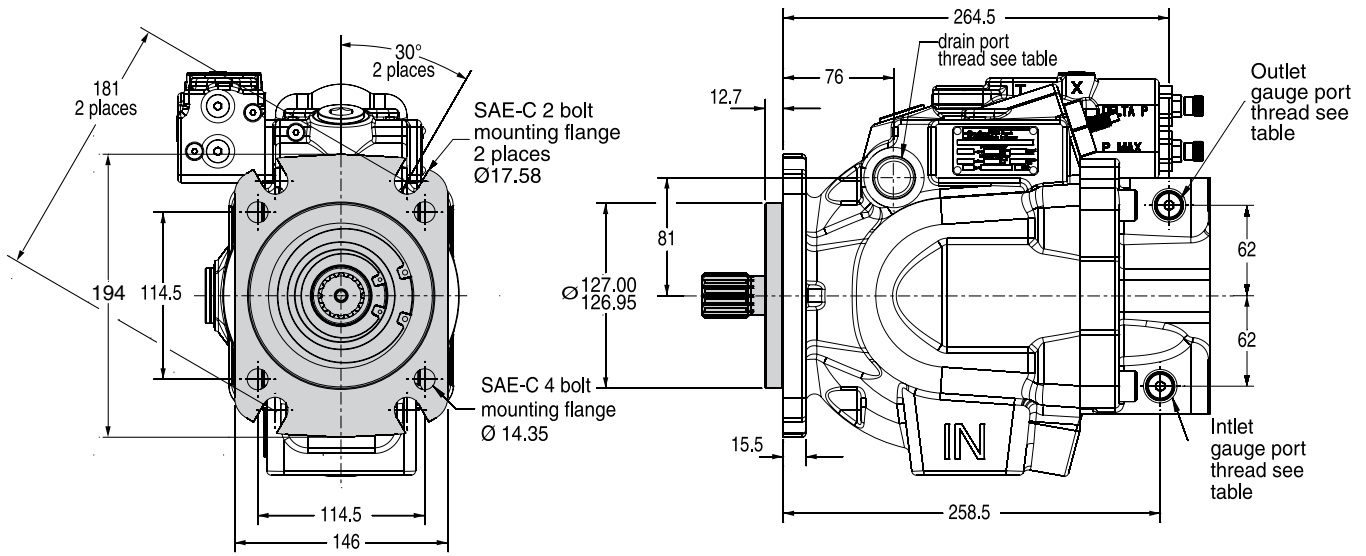

CW pump shown.  
 CCW pump will have inlet and outlet gauge ports reversed.



Port ordering code	Drain port	Inlet gauge port / Outlet gauge port
"A" side - UNC	SAE-12 straight thread / O-ring port: 1-1/16-12 UN thread	SAE-4 straight thread / O-ring port: 7/16-20 UN thread
"B" side - metric	ISO 6149 straight thread / O-ring port: M27 x 2 thread	ISO 6149 straight thread / O-ring port: M12 x 1.5 thread

**P2075 Side port**

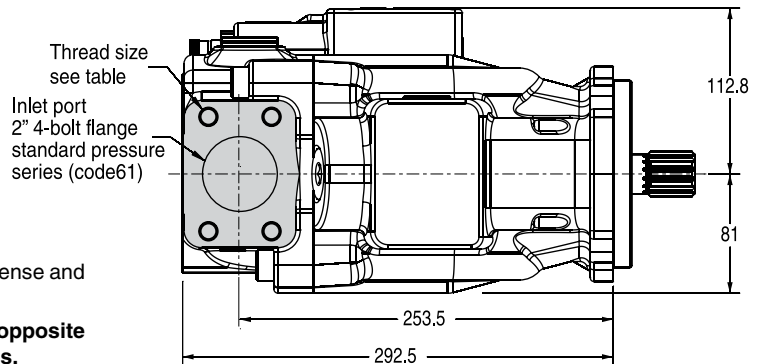
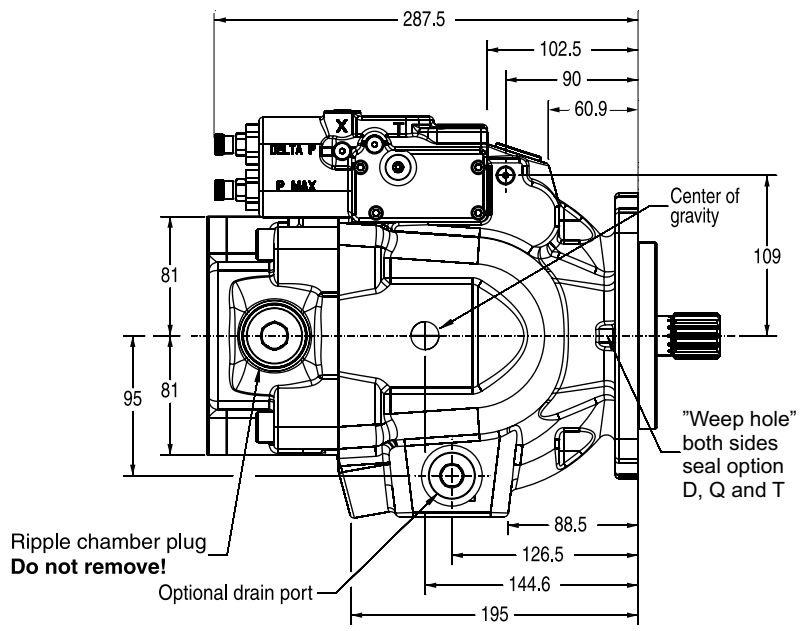
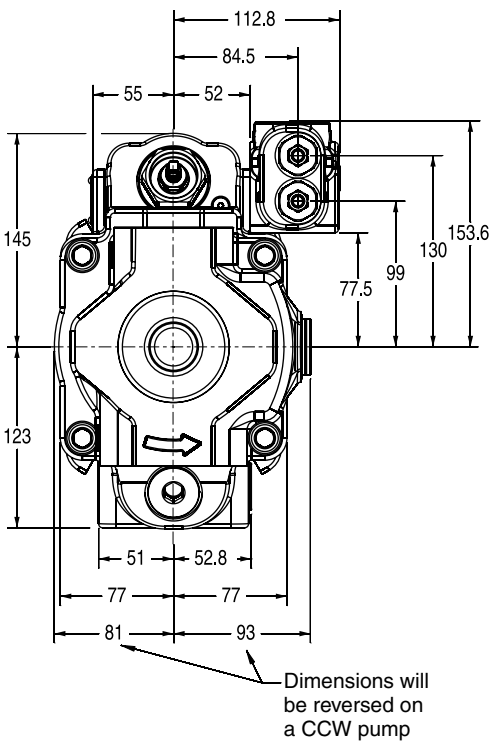
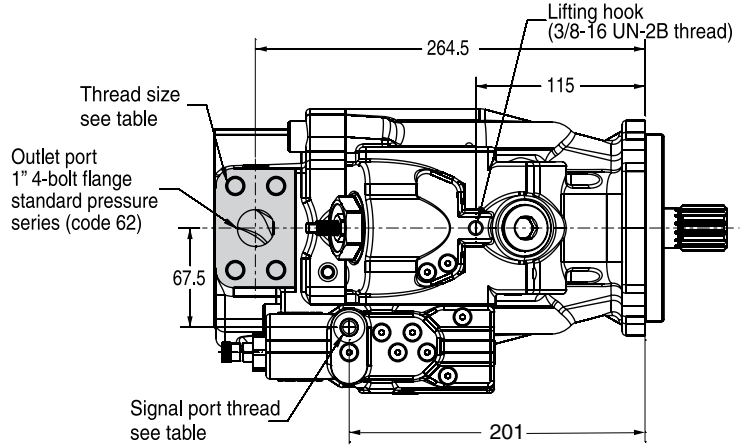

Pump shown is a CW rotation P2075 series pump with load sense and max. pressure compensator.

**As an option the compensator unit can be positioned at opposite side of the pump. Please consult manufacturer for details.**

CCW pump will have inlet and outlet gauge ports reversed.

Port option	Drain port	Inlet port	Outlet port	Inlet gauge port / Outlet gauge port / Signal port
"A" side - UNC	SAE-12 straight thread / O-ring port: 1-1/16-12 thread	1/2-13 UN	7/16-14 UN	SAE-4 straight thread / O-ring port: 7/16-20 UN thread
"B" side - metric	ISO 6149 straight thread / O-ring port: M27 x 2 thread	M12 x 1.75	M12 x 1.75	ISO 6149 straight thread / O-ring port: M12 x 1.5 thread

**P2075 Thru-drive option  
 A1 configuration**

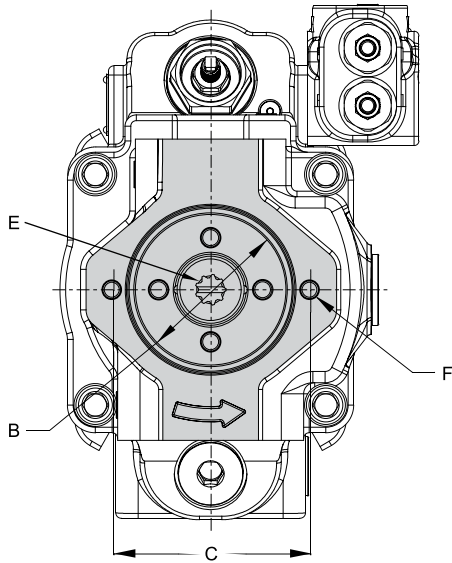

**B1 and B2 configurations**

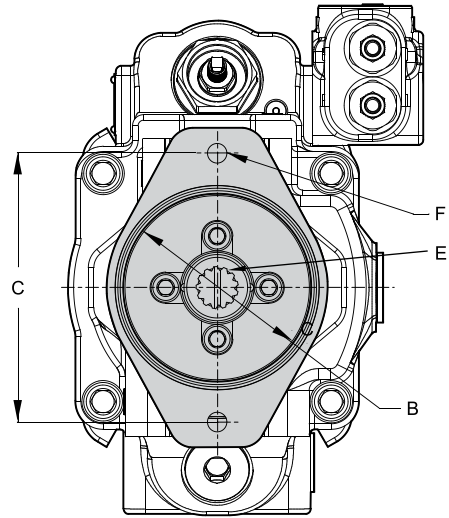

**C1 and C3 configurations**

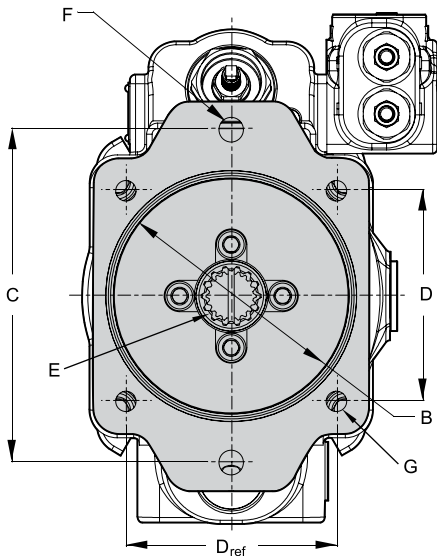

**P2075 partial cut-away of thru-drive area**

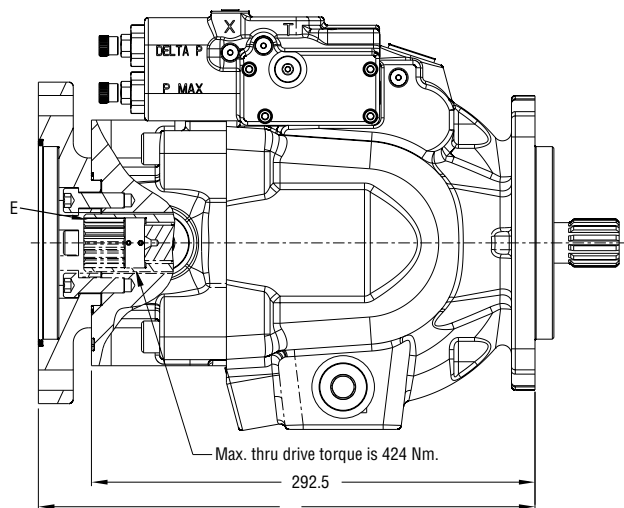

Pumps will be assembled with flange adapters as shown. Options B1, B2, C1 and C3 can be rotated 90°.

Thru-shaft option	A	B Ø	C	D	E	F UNC	F metric	G UNC	G metric	Weight
<b>A1</b>	292.5	82.625 82.575	106.38	N/A	SAE-A spline 9 tooth 16/32 pitch	3/8-16 UNC-2B THD	M10 x 1.5 THD	N/A	N/A	44 kg
<b>B1</b>	325.5	101.676 101.625	146.05	N/A	SAE-B spline 13 tooth 16/32 pitch	1/2-13 UNC-2B THD	M12 x 1.75 THD	N/A	N/A	46.5 kg
<b>B2</b>	325.5	101.676 101.625	146.05	N/A	SAE-BB spline 15 tooth 16/32 pitch	1/2-13 UNC-2B THD	M12 x 1.75 THD	N/A	N/A	46.5 kg
<b>C1 C3</b>	327.5	127.076 127.025	180.98	114.5	SAE-C spline 14 tooth 12/24 pitch	5/8-11 UNC-2B THD	M16 x 2 THD	1/2-13 UNC-2B THD	M12 x 1.75 THD	48 kg



**P2105 Mounting flange**

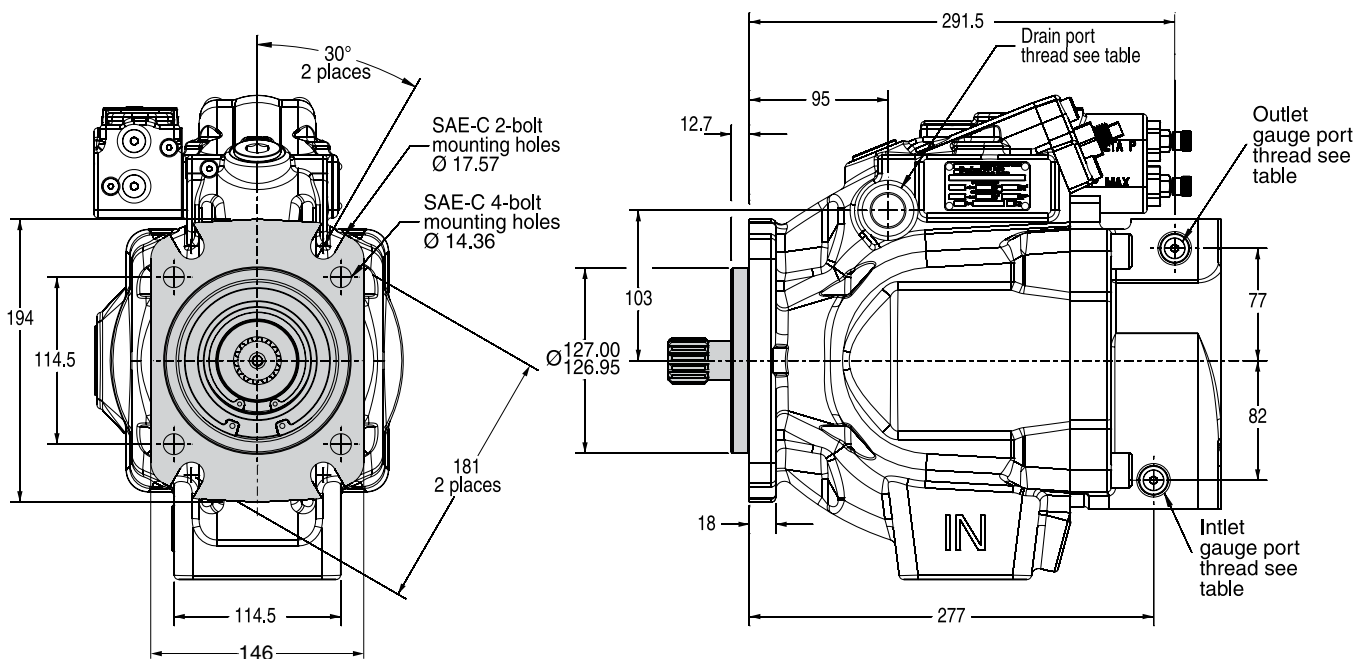

CW pump shown.  
 CCW pump will have inlet and outlet gauge ports reversed.

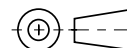

Port ordering code	Drain port	Inlet gauge port / Outlet gauge port
"A" side - UNC	SAE-12 straight thread / O-ring port: 1-1/16-12 UN thread	SAE-4 straight thread / O-ring port: 7/16-20 UN thread
"B" side - metric	ISO 6149 straight thread / O-ring port: M27 x 2 thread	ISO 6149 straight thread / O-ring port: M12 x 1.5 thread

**P2105 Side port**

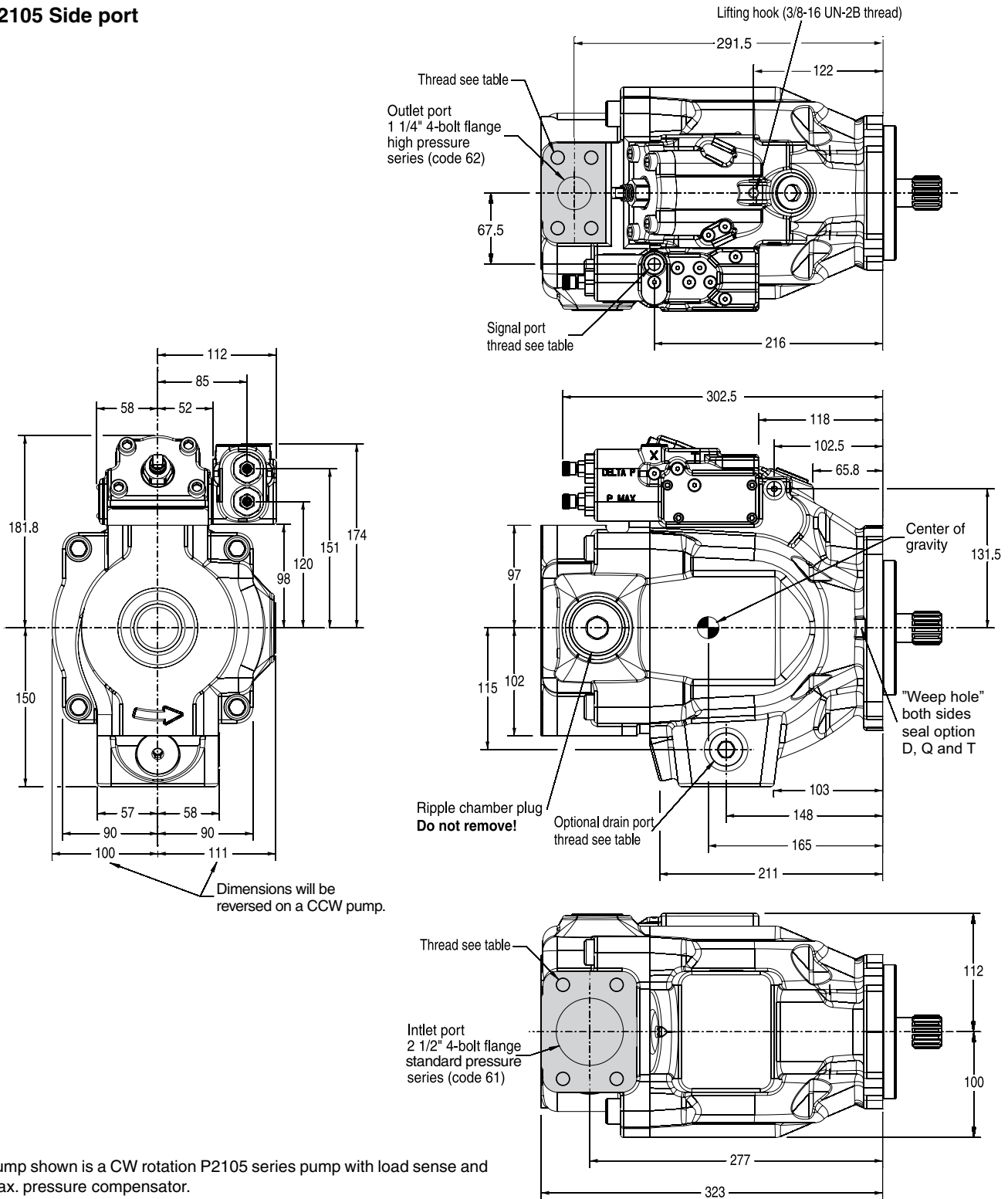

Pump shown is a CW rotation P2105 series pump with load sense and max. pressure compensator.

**As an option the compensator unit can be positioned at opposite side of the pump. Please consult manufacturer for details.**

CCW pump will have inlet and outlet gauge ports reversed.

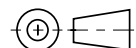

Port option	Drain port	Inlet port	Outlet port	Inlet gauge port / Outlet gauge port / Signal port
"A" side - UNC	SAE-12 straight thread / O-ring port: 1-1/16-12 thread	1/2-13 UN	1/2-13 UN	SAE-4 straight thread / O-ring port: 7/16-20 UN thread
"B" side - metric	ISO 6149 straight thread / O-ring port: M27 x 2 thread	M12 x 1.75	M12 x 1.75	ISO 6149 straight thread / O-ring port: M12 x 1.5 thread

**P2105 Thru-drive option  
 A1 configuration**

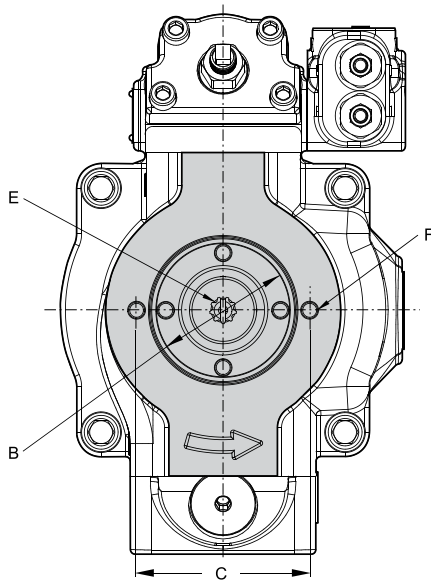

**B1 and B2 configurations**

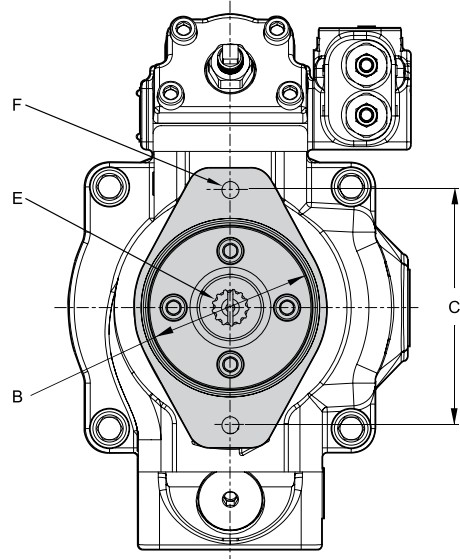

**C1 and C3 configurations**

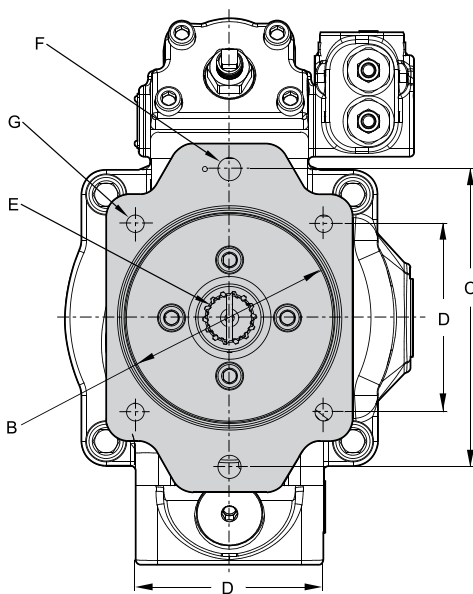

**P2105 partial cut-away of thru-drive area**

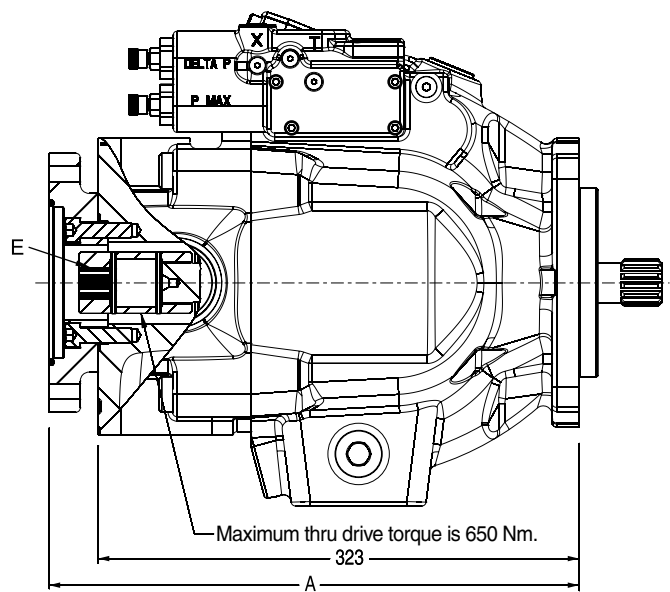

Pumps will be assembled with flange adapters as shown. Options B1, B2, C1 and C3 can be rotated 90°.

Thru-shaft option	A	B Ø	C	D	E	F UNC	F metric	G UNC	G metric	Weight
<b>A1</b>	323	82.625 82.575	106.38	N/A	SAE-A spline 9 tooth 16/32 pitch	3/8-16 UNC-2B THD	M10 x 1.5 THD	N/A	N/A	61 kg
<b>B1</b>	356	101.676 101.625	146.05	N/A	SAE-B spline 13 tooth 16/32 pitch	1/2-13 UNC-2B THD	M12 x 1.75 THD	N/A	N/A	64 kg
<b>B2</b>	356	101.676 101.625	146.05	N/A	SAE-BB spline 15 tooth 16/32 pitch	1/2-13 UNC-2B THD	M12 x 1.75 THD	N/A	N/A	64 kg
<b>C1, C3</b>	358	127.075 127.025	180.98	114.5	SAE-C spline 14 tooth 12/24 pitch	5/8-11 UNC-2B THD	M16 x 2 THD	1/2-13 UNC-2B THD	M12 x 1.75 THD	65 kg

**Dimensions**

**Axial Piston Pumps  
Series P2**

**P2145 Mounting flange  
SAE D 4-bolt mounting flange**

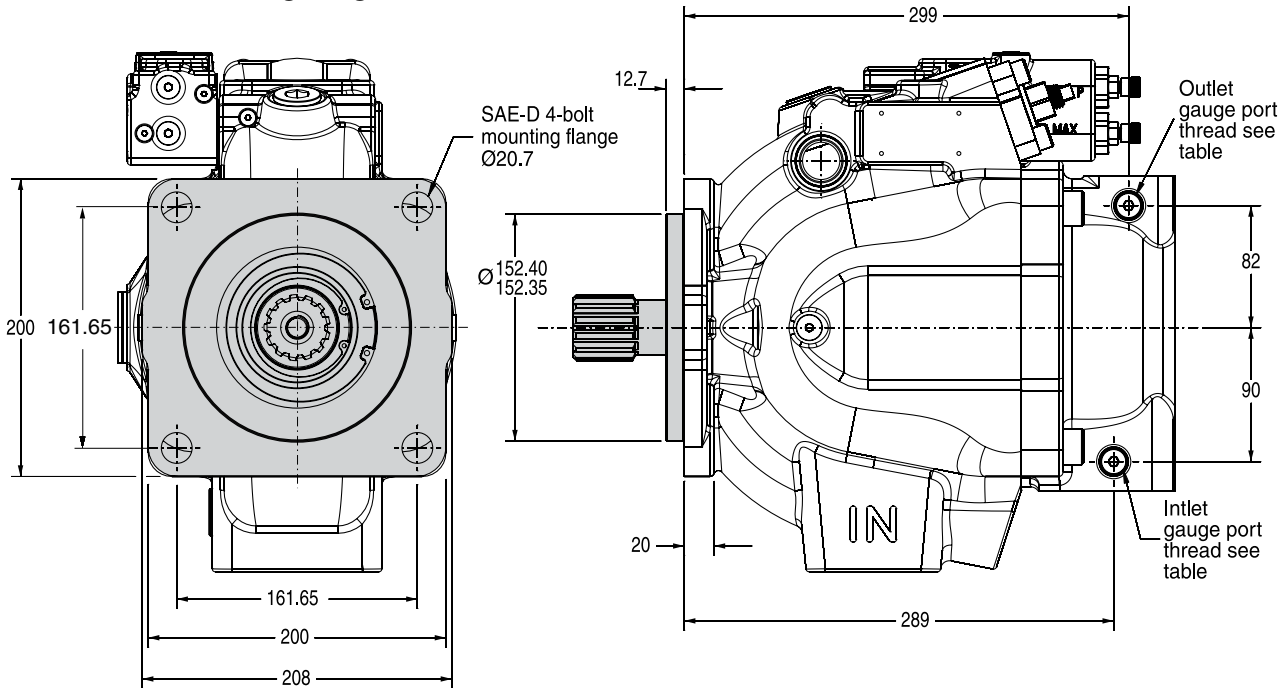

**SAE C 2-bolt mounting flange**

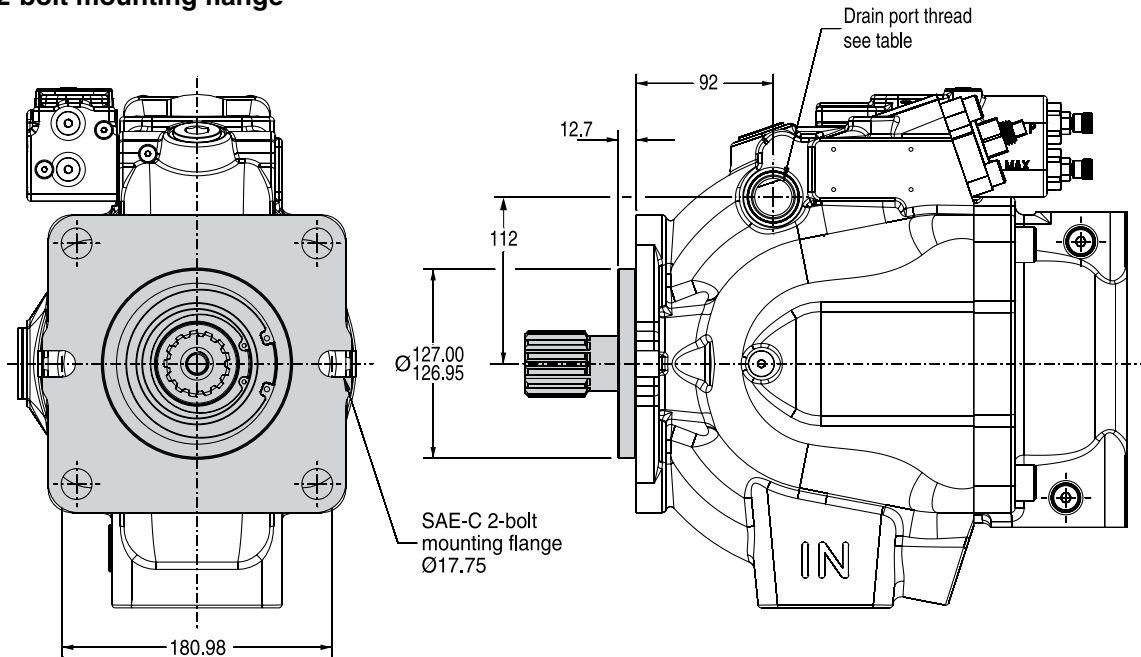

CW pump shown.  
CCW pump will have inlet and outlet gauge ports reversed.

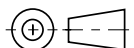

Port ordering code	Drain port	Inlet gauge port / Outlet gauge port
"A" side - UNC	SAE-12 straight thread / O-ring port: 1-1/16-12 UN thread	SAE-4 straight thread / O-ring port: 7/16-20 UN thread
"B" side - metric	ISO 6149 straight thread / O-ring port: M27 x 2 thread	ISO 6149 straight thread / O-ring port: M12 x 1.5 thread

**P2145 Side port**

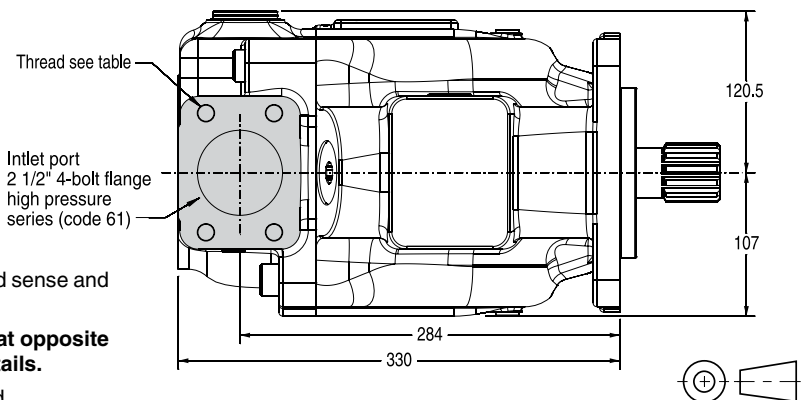
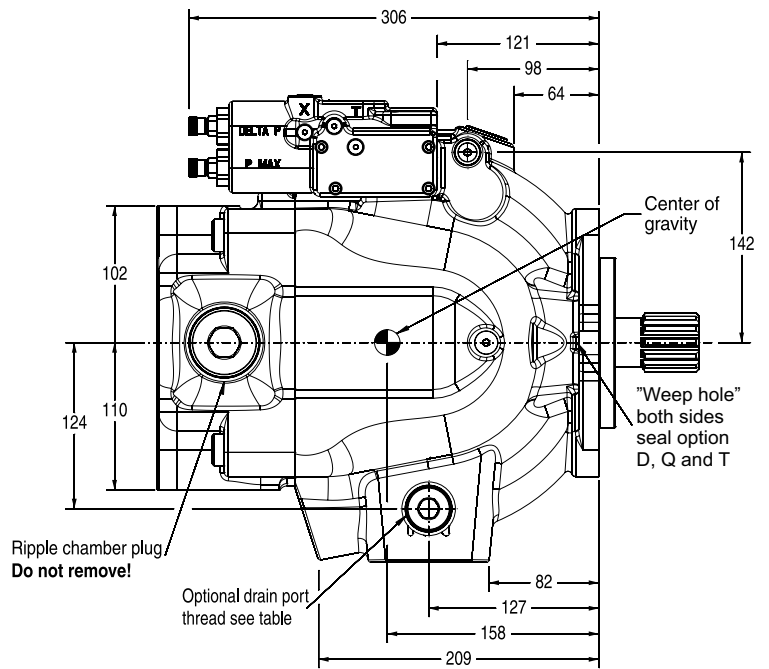
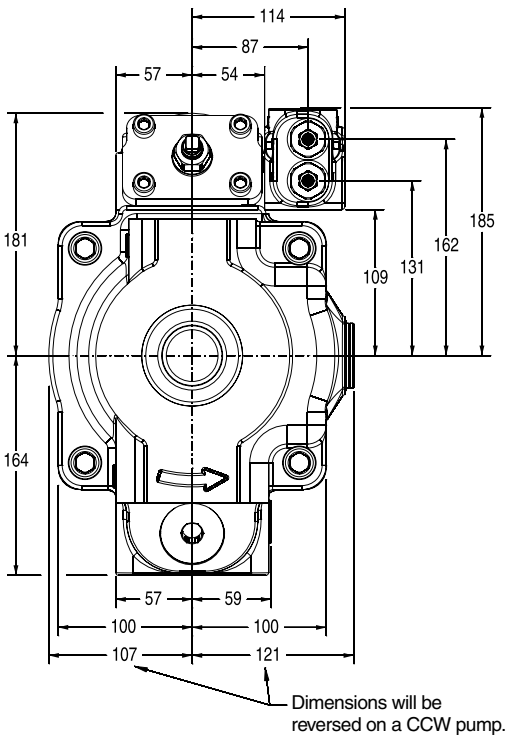
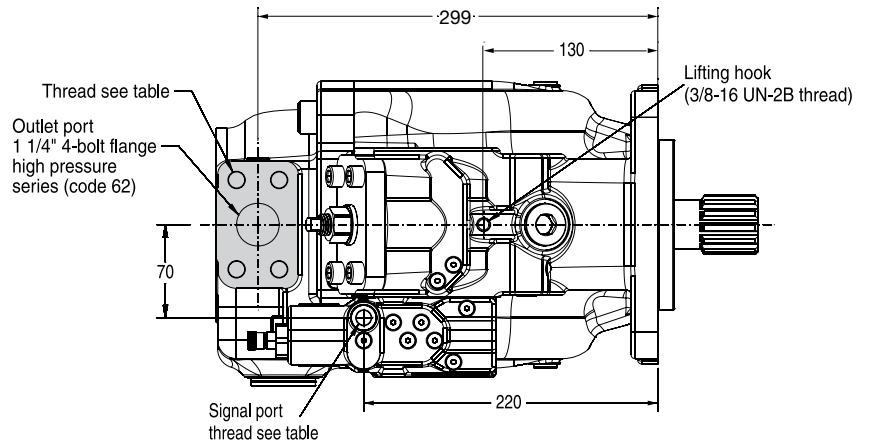

Pump shown is a CW rotation P2145 series pump with load sense and max. pressure compensator.

**As an option the compensator unit can be positioned at opposite side of the pump. Please consult manufacturer for details.**

CCW pump will have inlet and outlet gauge ports reversed.

Port option	Drain port	Inlet port	Outlet port	Inlet gauge port / Outlet gauge port / Signal port
"A" side - UNC	SAE-12 straight thread / O-ring port: 1-1/16-12 thread	1/2-13 UN	1/2-13 UN	SAE-4 straight thread / O-ring port: 7/16-20 UN thread
"B" side - metric	ISO 6149 straight thread / O-ring port: M27 x 2 thread	M12 x 1.75	M12 x 1.75	ISO 6149 straight thread / O-ring port: M12 x 1.5 thread

**P2145 Thru-drive option**  
**A1 configuration**

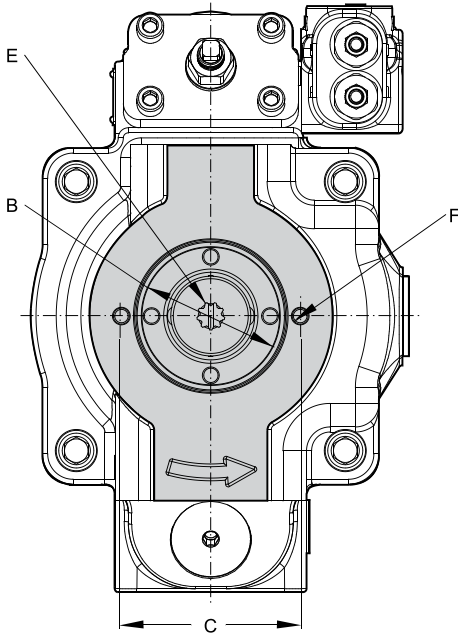

**B1 and B2 configurations**

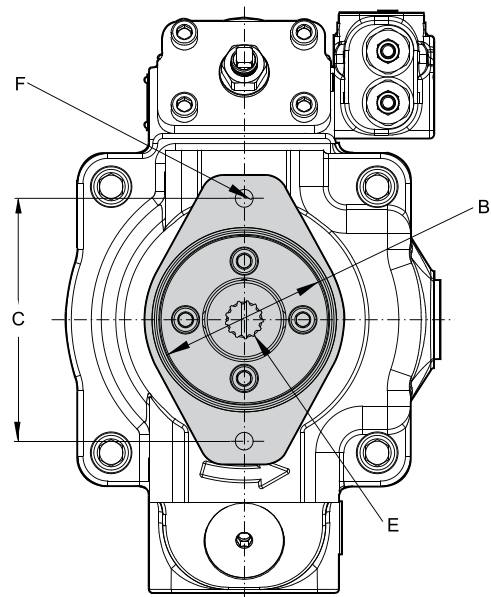

**C1, C2, C3 and C4 configurations**

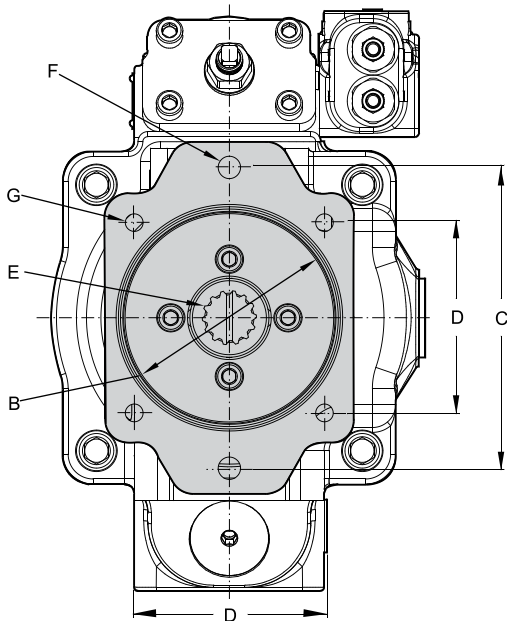

**D3 configuration**

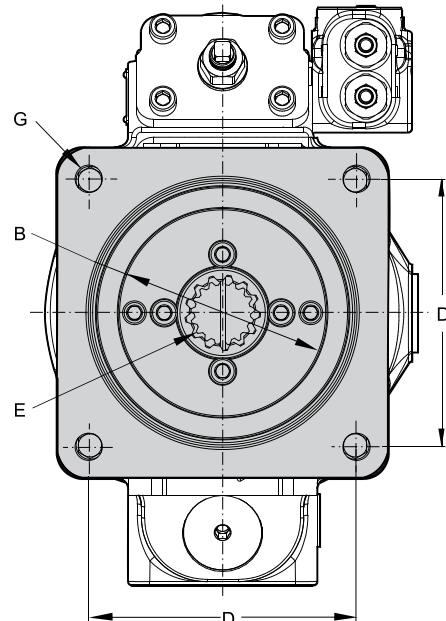

**P2145 Thru-drive option**

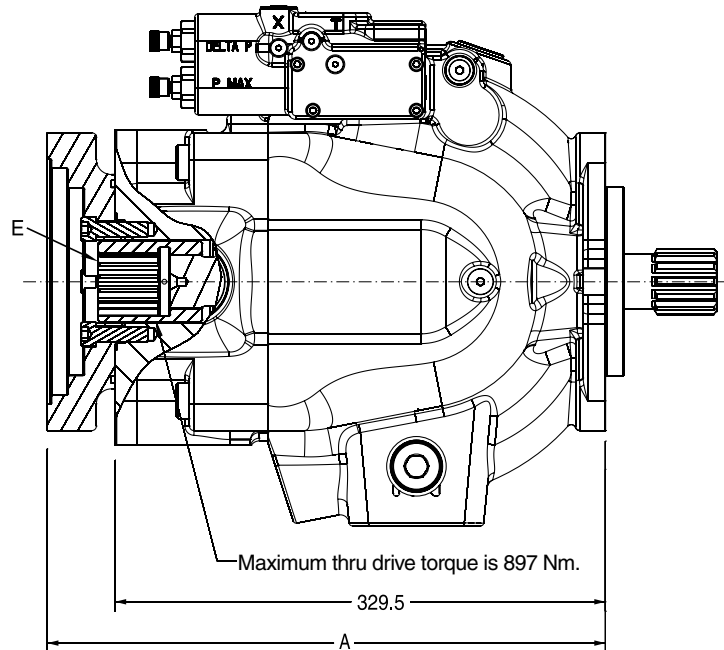

Thru-shaft option	A	B Ø	C	D	E	F UNC	F metric	G UNC	G metric	Weight
A1	329.5	82.626 82.575	106.38	N/A	SAE-A spline 9 tooth 16/32 pitch	3/8-16 UNC-2B THD	M10 x 1.5 THD	N/A	N/A	79.8 kg
B1	362.5	101.676 101.625	146.05	N/A	SAE-B spline 13 tooth 16/32 pitch	1/2-13 UNC-2B THD	M12 x 1.75 THD	N/A	N/A	82.6 kg
B2	362.5	101.676 101.625	146.05	N/A	SAE-BB spline 15 tooth 16/32 pitch	1/2-13 UNC-2B THD	M12 x 1.75 THD	N/A	N/A	82.6 kg
C1 & C2	364.5	127.075 127.025	180.98	NA	SAE-C spline 14 tooth 2/24 pitch	5/8-11 UNC-2B THD	M16 x 2 THD	1/2-13 UNC-2B THD	M12 x 1.75 THD	83.9 kg
C3	364.5	127.075 127.025	180.98	114.5	SAE-C spline 14 tooth 2/24 pitch	5/8-11 UNC-2B THD	M16 x 2 THD	1/2-13 UNC-2B THD	M12 x 1.75 THD	83.9 kg
C4	364.5	127.075 127.025	180.98	114.5	SAE-CC spline 17 tooth 2/24 pitch	5/8-11 UNC-2B THD	M16 x 2 THD	1/2-13 UNC-2B THD	M12 x 1.75 THD	83.9 kg
D3	375	152.475 152.425	NA	161.65	SAE-D spline 13 tooth 8/16 pitch	NA	NA	3/4-10 UNC-2B THD	M16 x 2 THD	88 kg

**P2 Shaft options**

**B1**

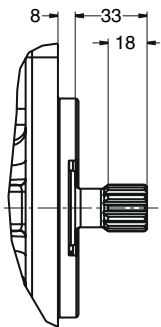

SAE "B" spline  
 13 tooth  
 16/32 pitch  
 30° involute spline  
 Max. input torque  
 209 Nm

**B2**

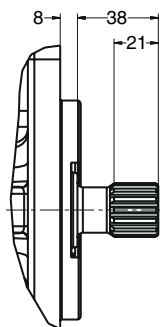

SAE "B-B" spline  
 15 tooth  
 16/32 pitch  
 30° involute spline  
 Max. input torque  
 337 Nm

**C1**

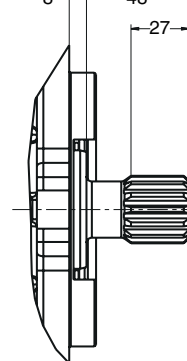

SAE "C" spline  
 14 tooth  
 12/24 pitch  
 30° involute spline  
 Max. input torque  
 641 Nm

**C2**

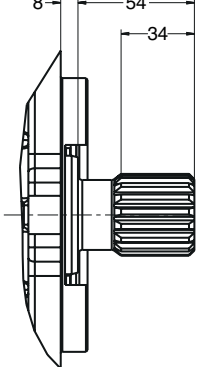

SAE "C-C" spline  
 17 tooth  
 12/24 pitch  
 30° involute spline  
 Max. input torque  
 1217 Nm

**C3**

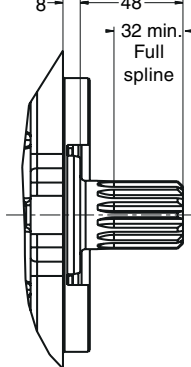

SAE "C" spline  
 no undercut  
 14 tooth  
 12/24 pitch  
 30° involute spline  
 Max. input torque  
 769 Nm

**D1**

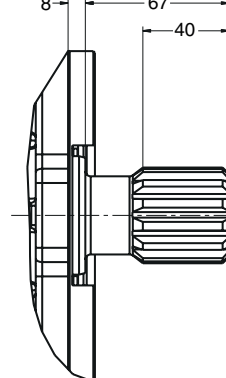

SAE D  
 13 tooth  
 8/16 pitch  
 30° involute spline  
 Max. input torque  
 1701 Nm

**D2**

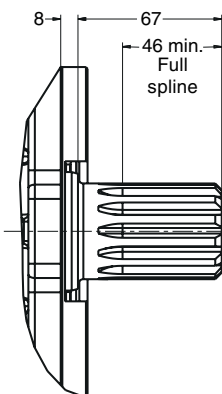

SAE "D" spline  
 no undercut  
 13 tooth  
 8/16 pitch  
 30° involute spline  
 Max. input torque  
 2041 Nm

**M6**

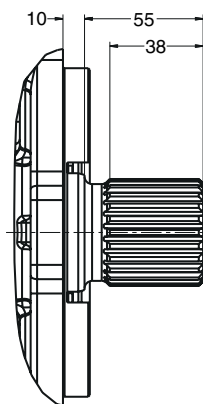

DIN 5480 spline  
 W50x2x30x24x9g  
 Max. input torque  
 3050 Nm

**Torque control dimensions**

Torque control options "TA", "TB", "TC" and "TD"

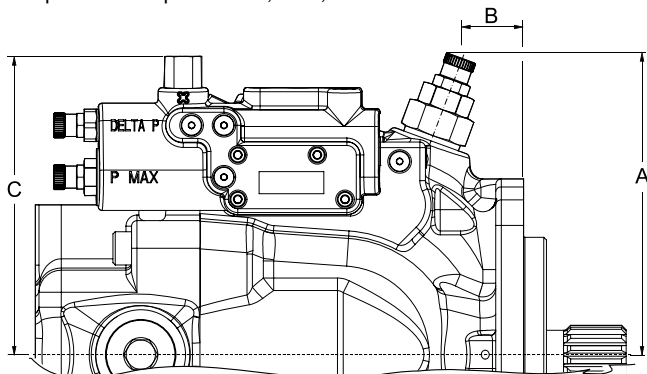

	P2060	P2075	P2105	P2145
A	163	171	190	202
B	34	69	69	69
C	161	154	175	186



**P3 Noise characteristics at max./min. displacement  
 P3105 Noise characteristics**

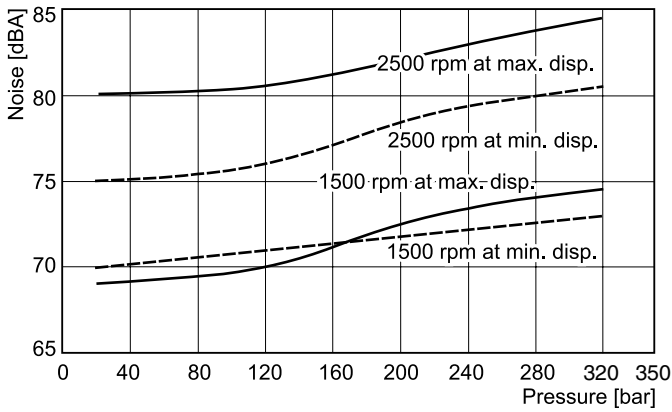

**P3 Series - typical drive power at full displacement  
 P3105 Input power - full stroke**

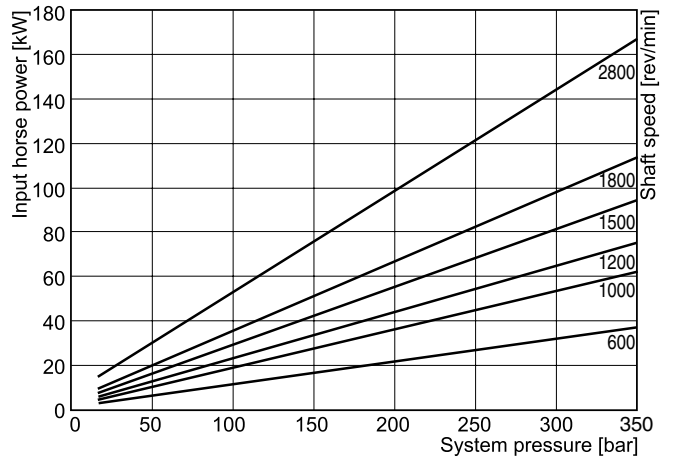

**P3145 Noise characteristics**

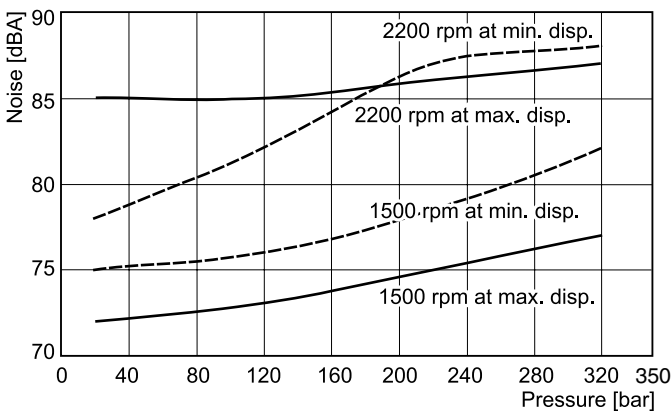

**P3145 Input power - full stroke**

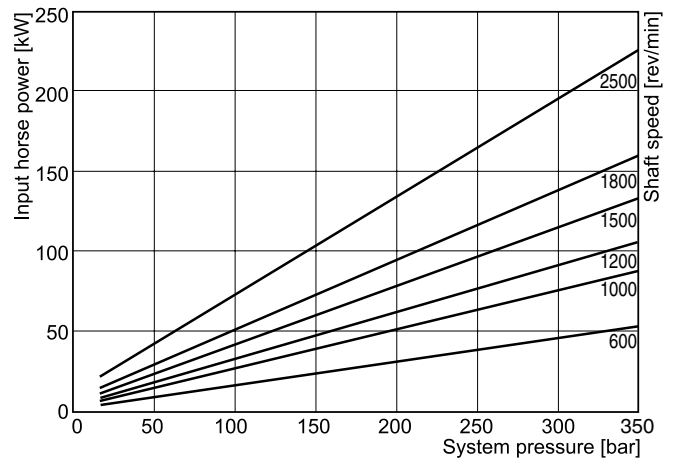

Fluid: Mineral oil ISO VG 32 at 40°C ; Inlet pressure: 1.0 bar (absolute) measured at inlet port.

**P3 Series - typical compensated input power  
 P3105 Input power - zero stroke**

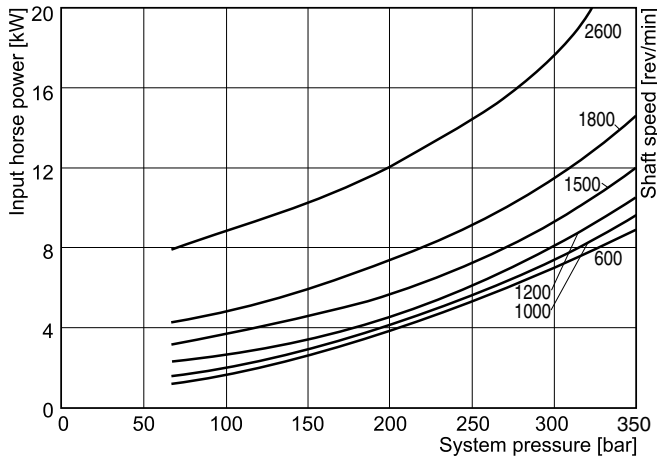

**P3 Series - typical efficiency at full displ. at 1800 rpm  
 P3105 Efficiency at 1800 rpm**

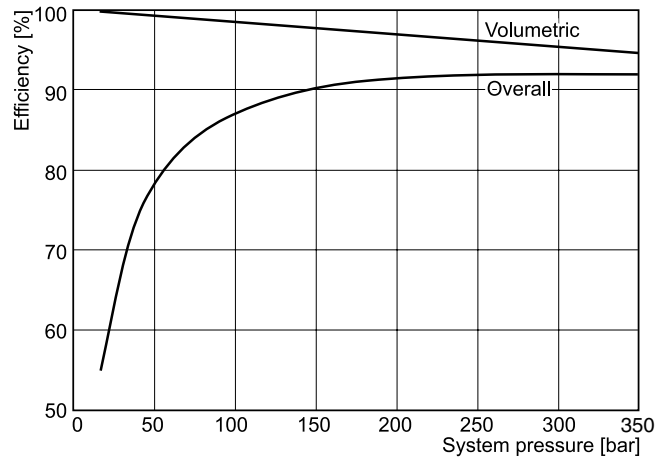

**P3145 Input power - zero stroke**

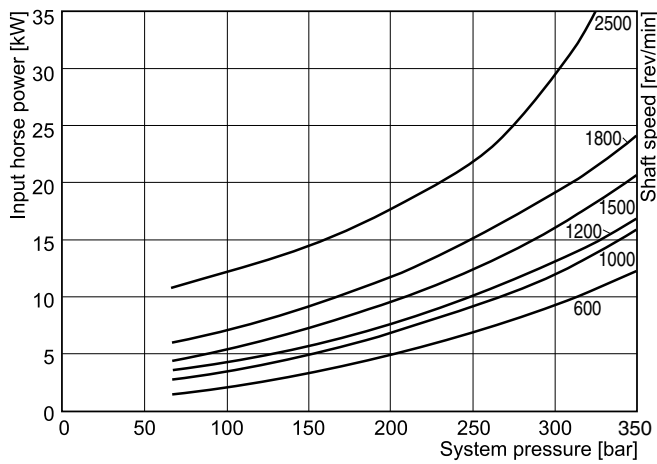

**P3145 Efficiency at 1800 rpm**

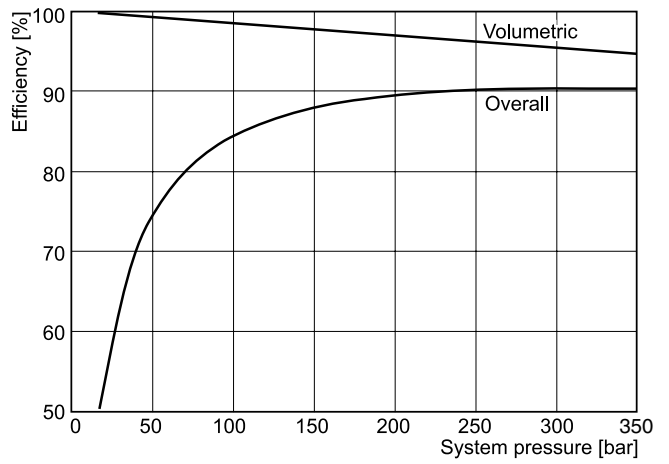

Fluid: Mineral oil ISO VG 32 at 40°C ; Inlet pressure: 1.0 bar (absolute) measured at inlet port.

**P3 Series - typical flow vs. pressure**  
**P3105 Outlet flow - full stroke**

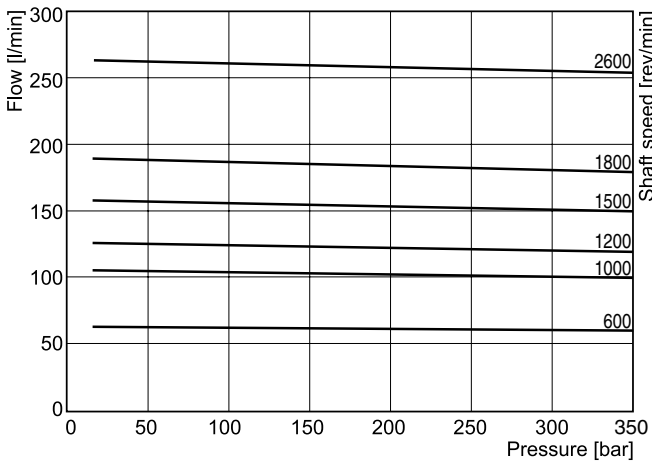

**P3 Series - typical compensated drain flow**  
**P3105 Drain flow at zero stroke**

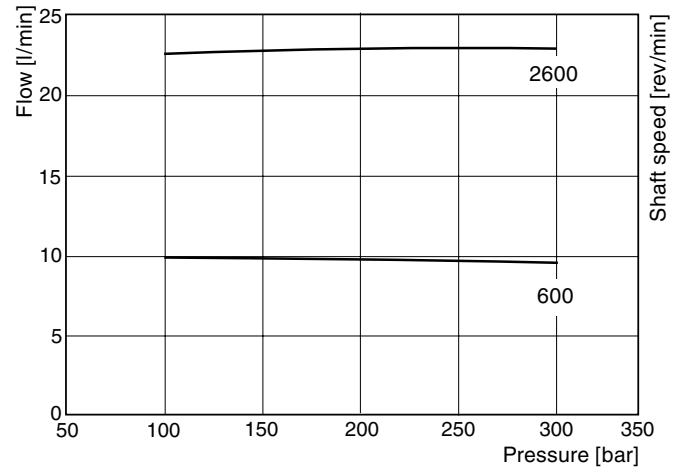

**P3145 Outlet flow - full stroke**

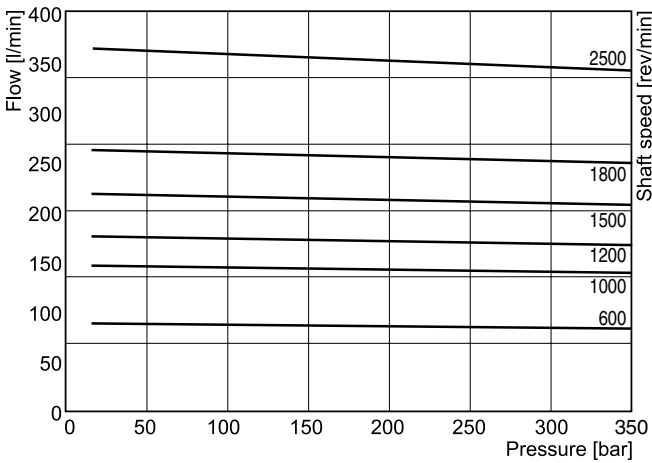

**P3145 Drain flow at zero stroke**

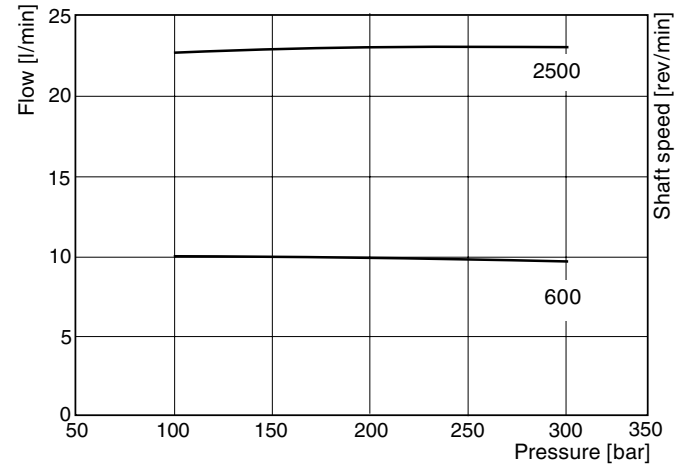

Fluid: Mineral oil ISO VG 32 at 40°C ; Inlet pressure: 1.0 bar (absolute) measured at inlet port.

**P3 Series - typical inlet characteristics vs. speed at various percentage displacements**

**P3105 Inlet characteristics**

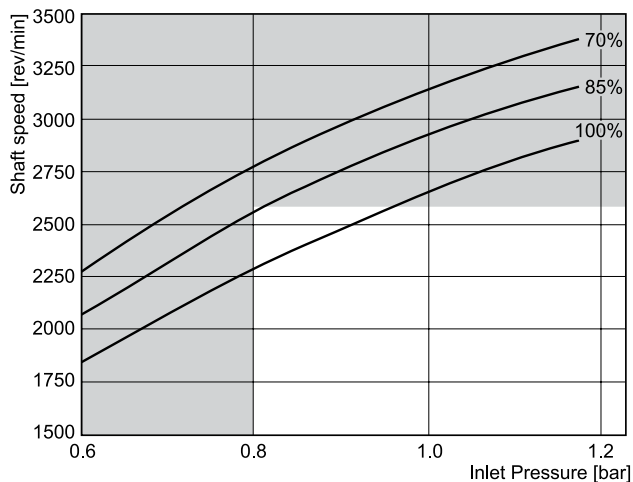

**P3145 Inlet characteristics**

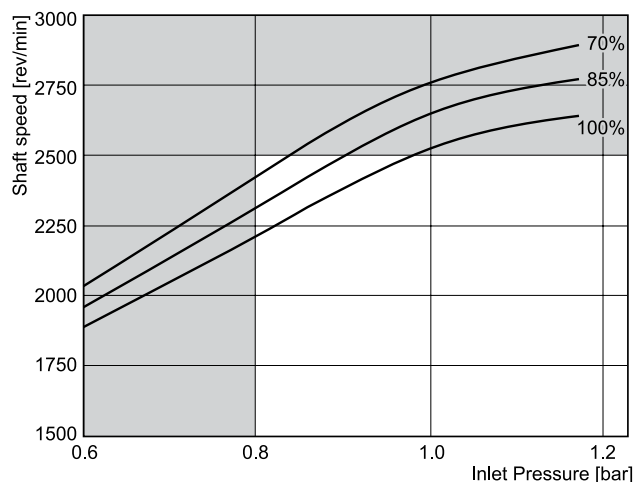

Fluid: Mineral oil ISO VG 32 at 40°C ; Inlet pressure: 1.0 bar (absolute) measured at inlet port.

 For operation at these speeds, please consult manufacturer for approval.

**P3105 Mounting flange**

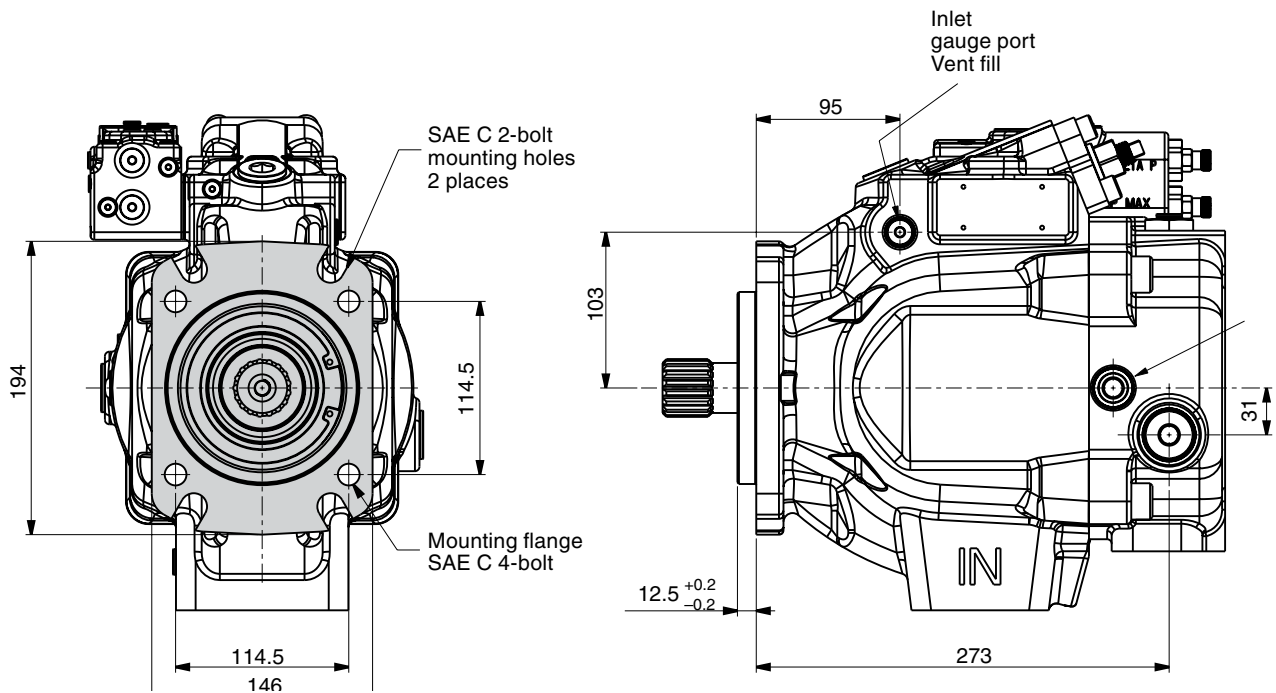

CW pump shown  
 CCW pump will have outlet gauge port at opposite side

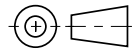

Port ordering code	Drain port	Airbleed port / vent port
"A" side - UNC	SAE-8 straight thread / O-ring port: 3/4 - 16 UN thread	SAE-4 straight thread / O-ring port: 7/16-20 UN thread
"B" side - metric	ISO 6149 straight thread / O-ring port: M18 x 1.5 thread	ISO 6149 straight thread / O-ring port: M12 x 1.5 thread

**P3105 Side port**

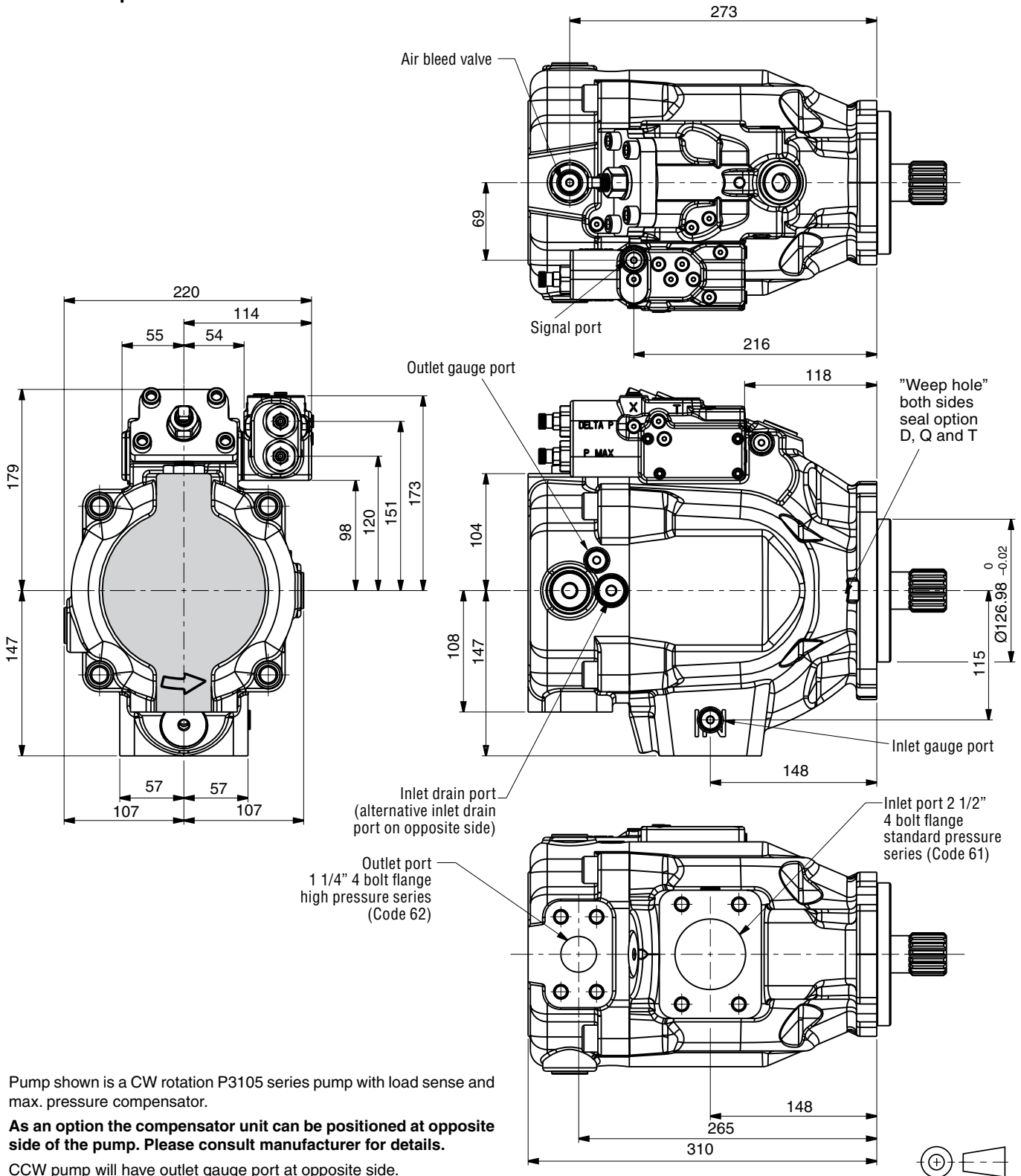

Pump shown is a CW rotation P3105 series pump with load sense and max. pressure compensator.

**As an option the compensator unit can be positioned at opposite side of the pump. Please consult manufacturer for details.**

CCW pump will have outlet gauge port at opposite side.

Port ordering code	Drain port	Inlet port	Outlet port	Inlet gauge port / Outlet gauge port / Airbleed port / Signal port
"A" side - UNC	SAE 8 straight thread / O-ring port: 3/4 - 16 UN thread	1/2-13 UNC	1/2-13 UNC	SAE-4 straight thread / O-ring port: 7/16-20 UN thread
"B" side - metric	ISO 6149 straight thread / O-ring port: M18 x 1.5 thread	M12 x 1.75	M12 x 1.75	ISO 6149 straight thread / O-ring port: M12 x 1.5 thread

**P3105 Thru-drive option**

**A1 Configuration**

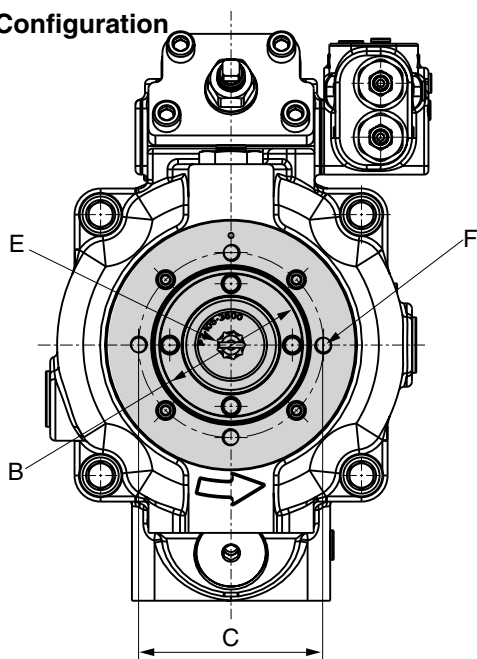

**B1 and B2 Configuration**

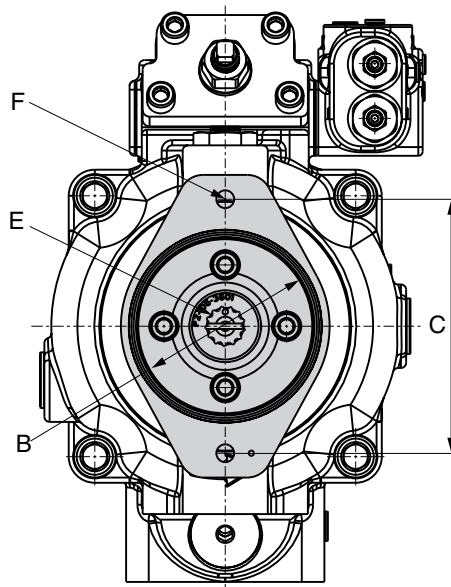

**C1 and C3 Configuration**

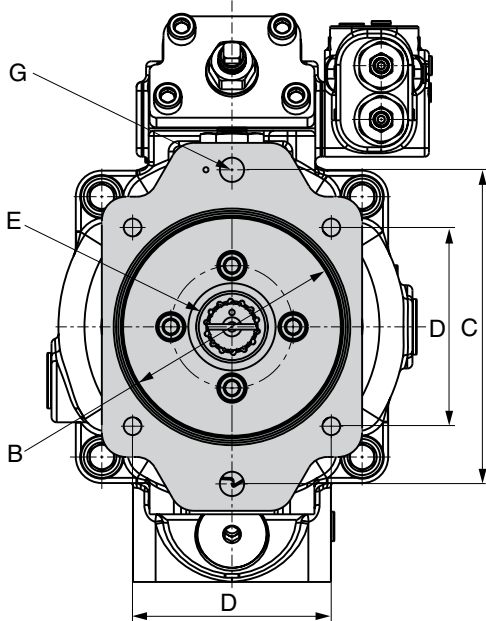

**P3105 Partial cut-away of thru-drive area**

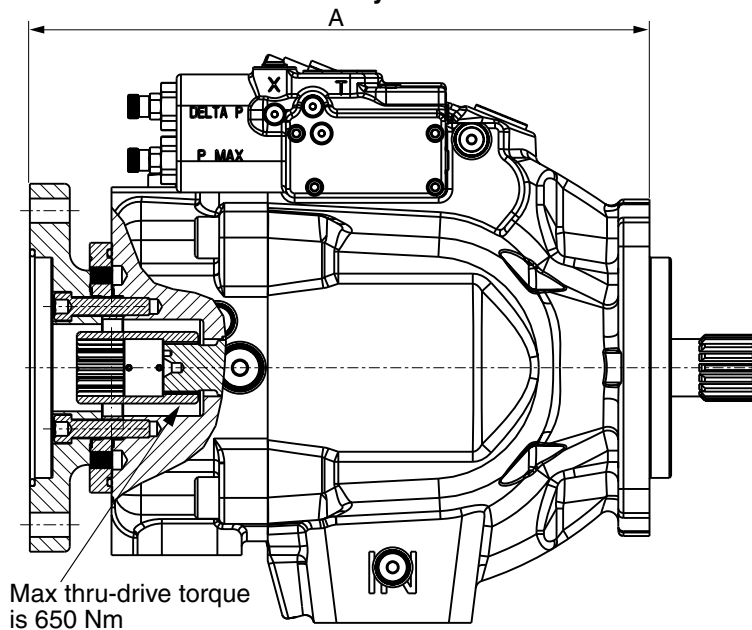

Thru-shaft option	A	B Ø	C	D	E	F UNC	F metric	G UNC	G metric	Weight
<b>A1</b>	323	82.626 82.575	106.3	N/A	SAE-A spline 9 tooth 16/32 pitch	3/ 16 UNC-2B THD	M10 x 1.5 THD	N/A	N/A	63 kg
<b>B1</b>	356	101.676 101.625	146.1	N/A	SAE-B spline 13 tooth 16/32 pitch	1/2-13 UNC-2B THD	M12 x 1.75 THD	N/A	N/A	64 kg
<b>B2</b>	356	101.676 101.625	146.1	N/A	SAE-BB spline 15 tooth 16/32 pitch	1/2-13 UNC-2B THD	M12 x 1.75 THD	N/A	N/A	64 kg
<b>C1 C3</b>	358	127.075 127.025	181	114.5	SAE-C spline 14 tooth 12/24 pitch	1/2-13 UNC-2B THD	M12 x 1.75 THD	5/8-11 UNC- 2B THD	M16 x 2 THD	66 kg

**P3145 Mounting flange  
 SAE C 2-bolt mounting flange**

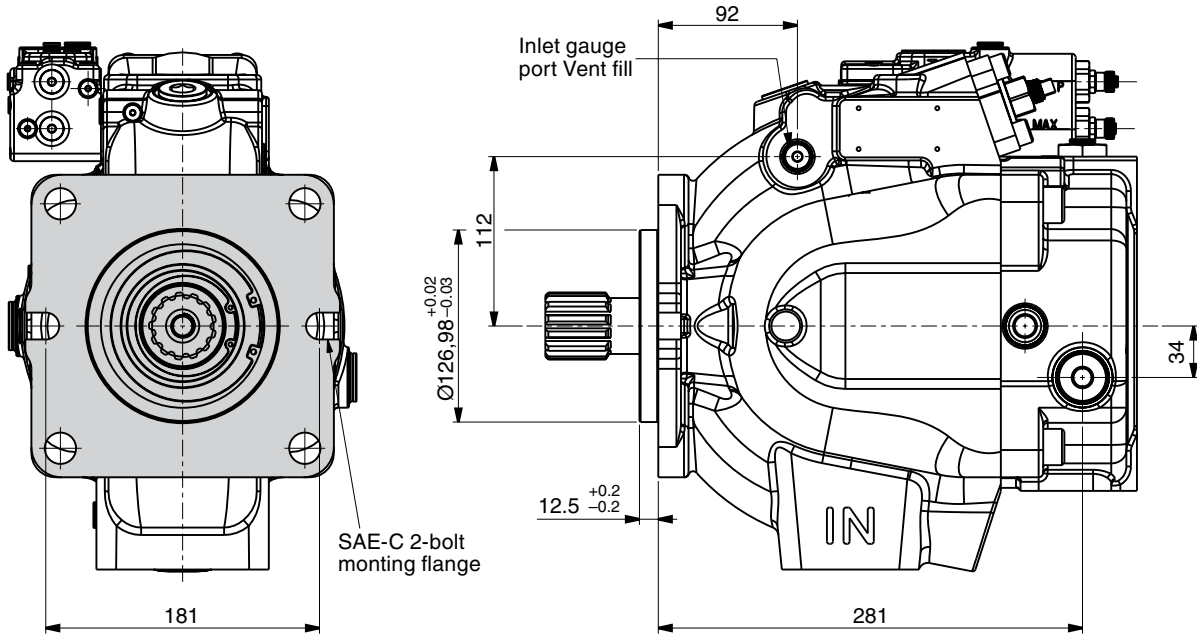

**SAE D 4-bolt mounting flange**

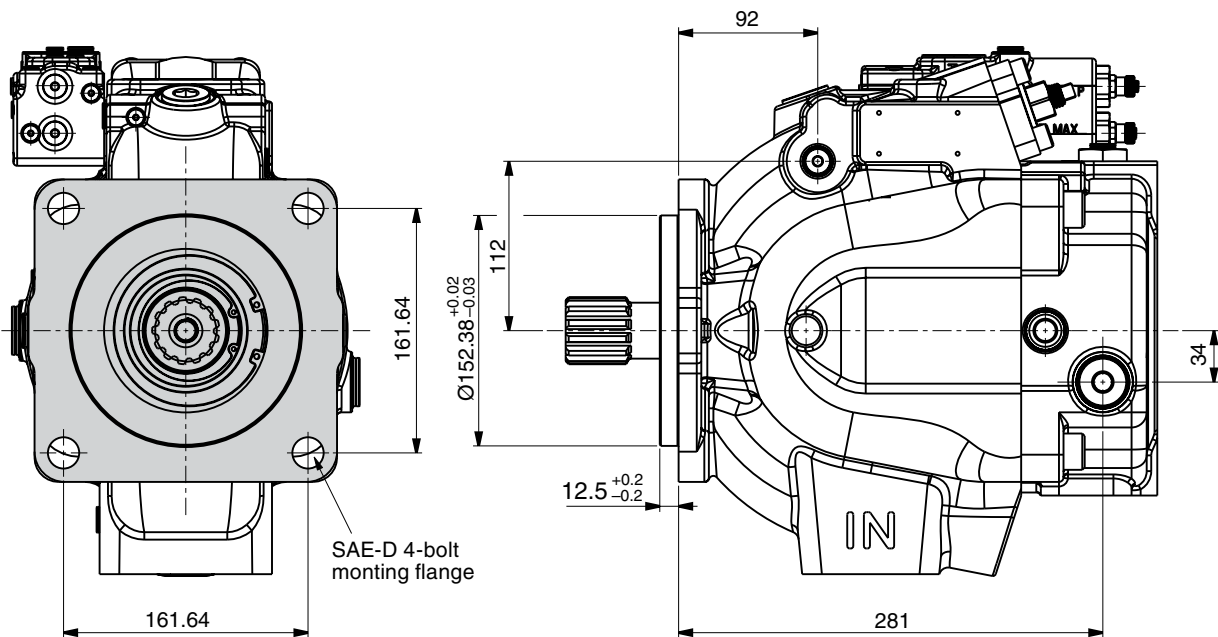

CW pump shown  
 CCW pump will have outlet gauge port at opposite side

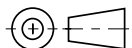

Port ordering code	Drain port	Airbleed port / vent port
"A" side - UNC	SAE 8 straight thread / O-ring port: 3/4 - 16 UN thread	SAE-4 straight thread / O-ring port: 7/16-20 UN thread
"B" side - metric	ISO 6149 straight thread / O-ring port: M18 x 1.5 thread	ISO 6149 straight thread / O-ring port: M12 x 1.5 thread



**P3145 Side port**

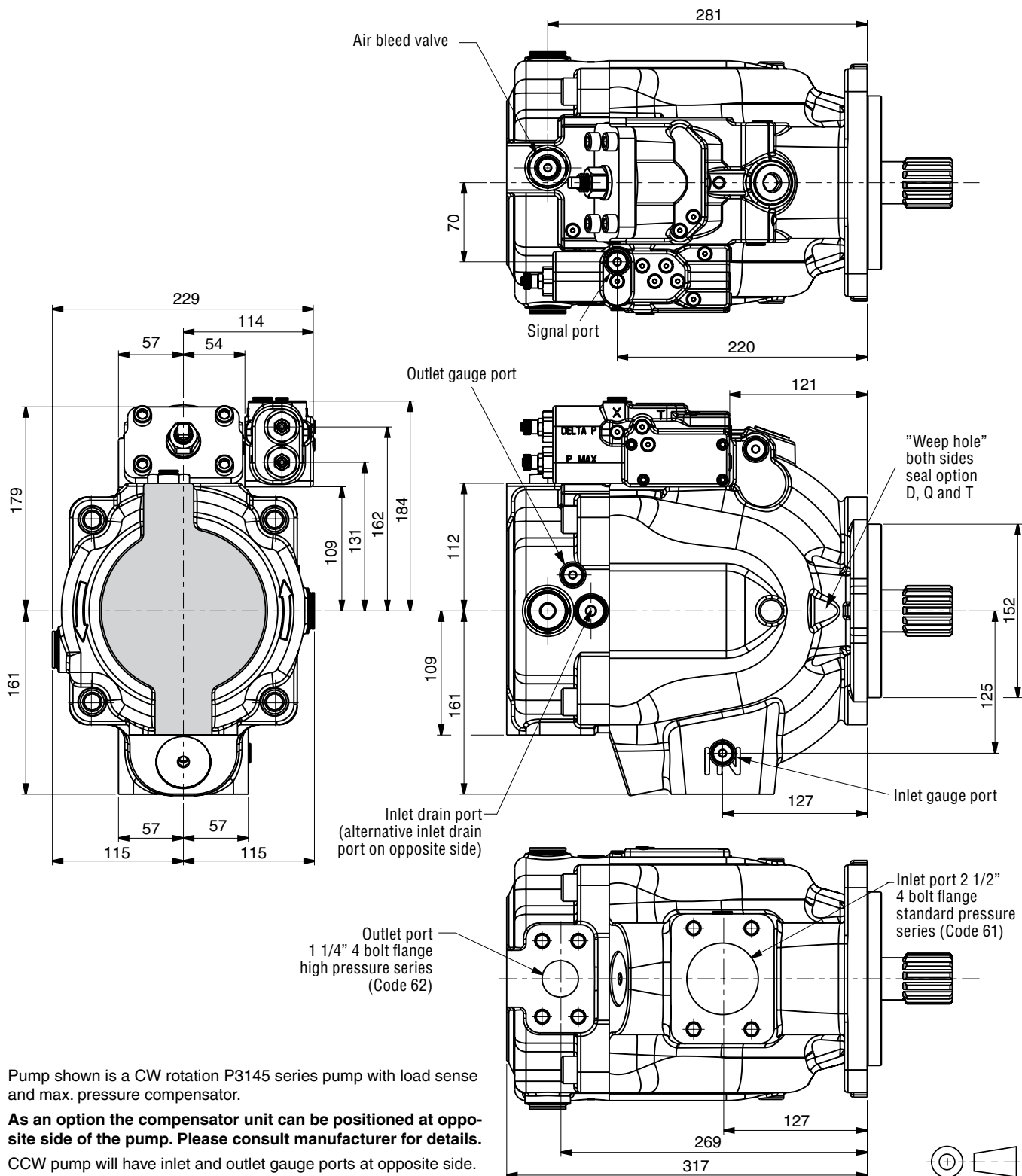

Pump shown is a CW rotation P3145 series pump with load sense and max. pressure compensator.

**As an option the compensator unit can be positioned at opposite side of the pump. Please consult manufacturer for details.**  
 CCW pump will have inlet and outlet gauge ports at opposite side.

Port ordering code	Drain port	Inlet port	Outlet port	Inlet gauge port / Outlet gauge port / Airbleed port / Signal port
"A" side - UNC	SAE 8 straight thread / O-ring port: 3/4 - 16 UN thread	1/2-13 UNC	1/2-13 UNC	SAE-4 straight thread / O-ring port: 7/16-20 UN thread
"B" side - metric	ISO 6149 straight thread / O-ring port: M18 x 1.5 thread	M12 x 1.75	M12 x 1.75	ISO 6149 straight thread / O-ring port: M12 x 1.5 thread

**P3145 Thru-drive option  
A1 Configuration**

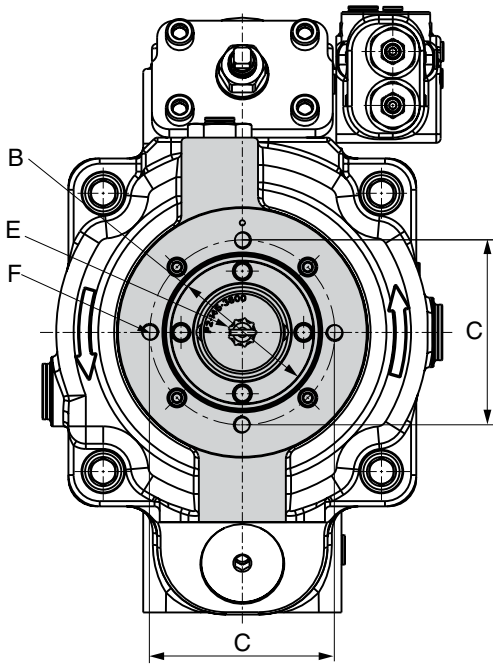

**B1 and B2 Configuration**

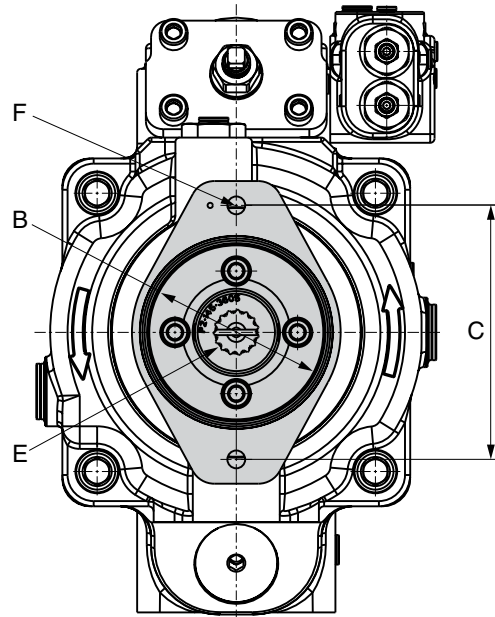

**C1, C2, C3 and C4 Configuration**

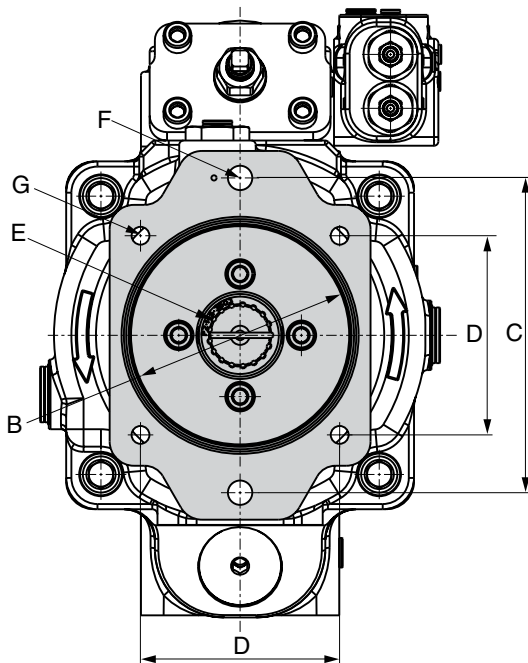

**D3 Configuration**

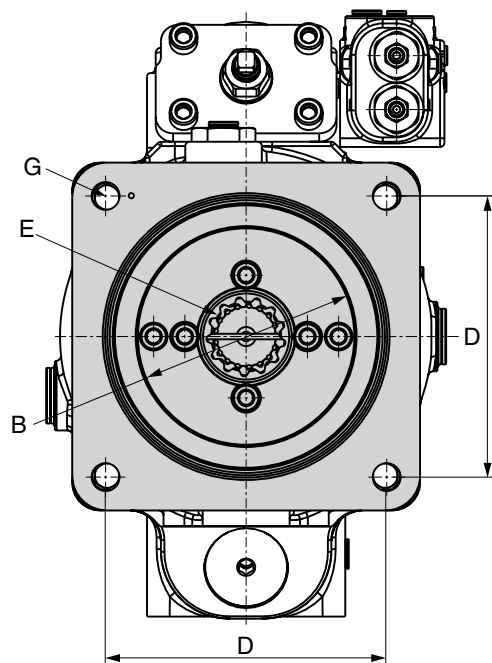

**P3145 Thru-drive option**

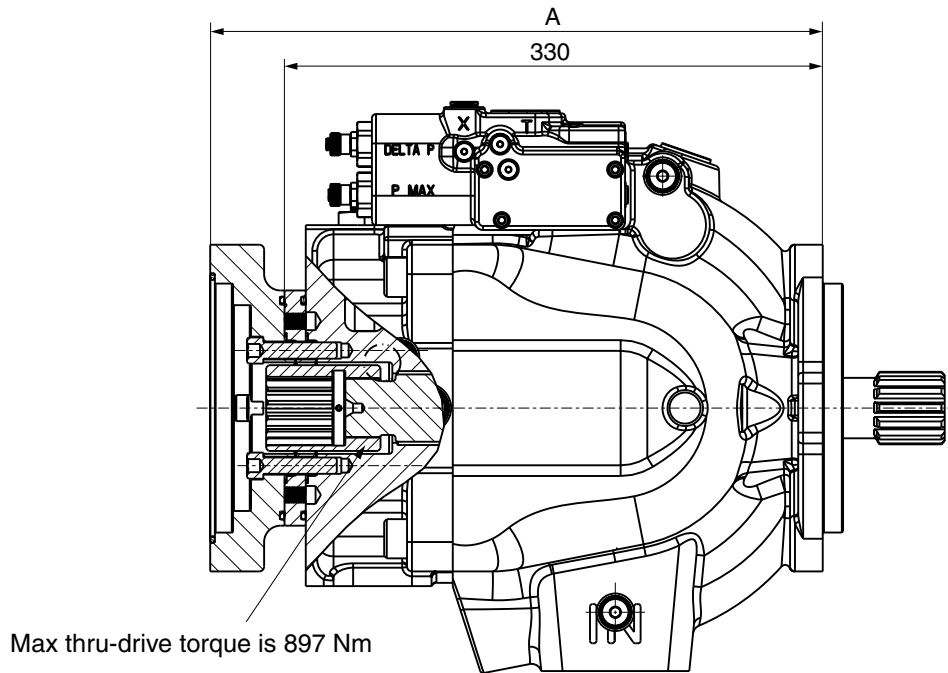

Thru-shaft option	A	B Ø	C	D	E	F UNC	F metric	G UNC	G metric	Weight
<b>A1</b>	329.5	82.626 82.575	106.38	N/A	SAE-A spline 9 tooth 16/32 pitch	3/8-16 UNC-2B THD	M10 x 1.5 THD	N/A	N/A	75.9 kg
<b>B1</b>	362.5	101.676 101.625	146.05	N/A	SAE-B spline 13 tooth 16/32 pitch	1/2-13 UNC-2B THD	M12 x 1.75 THD	N/A	N/A	78.5 kg
<b>B2</b>	362.5	101.676 101.625	146.05	N/A	SAE-BB spline 15 tooth 16/32 pitch	1/2-13 UNC-2B THD	M12 x 1.75 THD	N/A	N/A	78.5 kg
<b>C1</b>	364.5	127.075 127.025	180.98	NA	SAE-C spline 14 tooth 12/24 pitch	5/8-11 UNC-2B THD	M16 x 2 THD	1/2-13 UNC-2B THD	M12 x 1.75 THD	80 kg
<b>C2</b>	364.5	127.075 127.025	180.98	NA	SAE-C spline 17 tooth 12/24 pitch	5/8-11 UNC-2B THD	M16 x 2 THD	1/2-13 UNC-2B THD	M12 x 1.75 THD	80 kg
<b>C3</b>	364.5	127.075 127.025	180.98	114.5	SAE-C spline 14 tooth 12/24 pitch	5/8-11 UNC-2B THD	M16 x 2 THD	1/2-13 UNC-2B THD	M12 x 1.75 THD	80 kg
<b>C4</b>	364.5	127.075 127.025	180.98	114.5	SAE-CC spline 17 tooth 12/24 pitch	5/8-11 UNC-2B THD	M16 x 2 THD	1/2-13 UNC-2B THD	M12 x 1.75 THD	80 kg
<b>D3</b>	375	152.475 152.425	NA	161.65	SAE-D spline 13 tooth 8/16 pitch	NA	NA	3/4-10 UNC-2B THD	M16 x 2 THD	83.7 kg

**Dimensions**

**P3 Shaft options**

**C1**

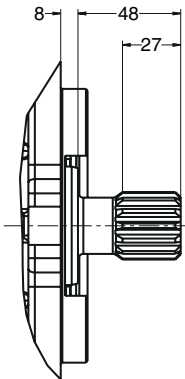

SAE "C" spline  
14 tooth  
12/24 pitch  
30° involute spline  
Max. input torque  
641 Nm

**C2**

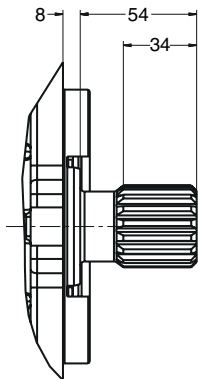

SAE "C-C" spline  
17 tooth  
12/24 pitch  
30° involute spline  
Max. input torque  
1217 Nm

**C3**

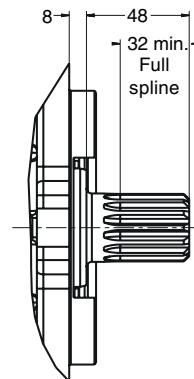

SAE "C" spline  
no undercut  
14 tooth  
12/24 pitch  
30° involute spline  
Max. input torque  
769 Nm

**D1**

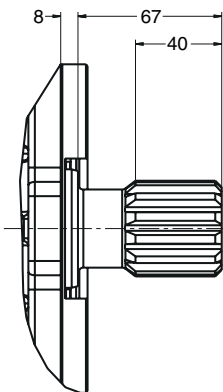

SAE D  
13 tooth  
8/16 pitch  
30° involute spline  
Max. input torque  
1701 Nm

**D2**

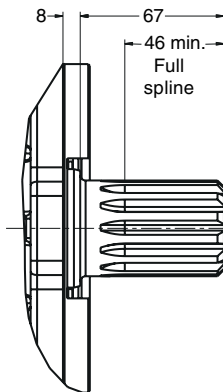

SAE "D" spline  
no undercut  
13 tooth  
8/16 pitch  
30° involute spline  
Max. input torque  
2041 Nm

**M6**

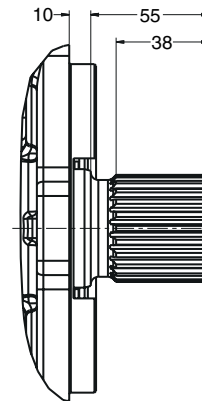

DIN 5480 spline  
W50x2x30x24x9g  
Max. input torque  
3050 Nm

**Torque control dimensions**

Torque control options "TA", "TB", "TC" and "TD"

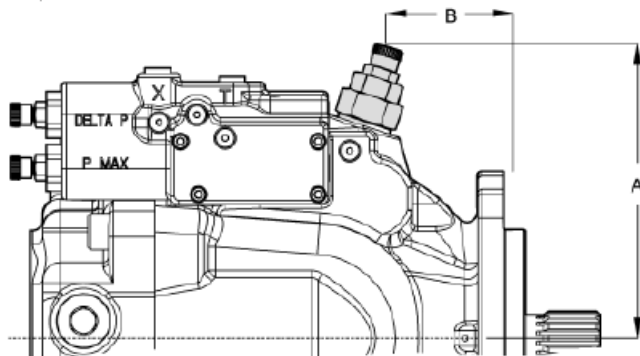

	P3105	P3145
<b>A</b>	190	202
<b>B</b>	69	69

**Multiple pump combinations - Maximum moment**

To avoid excessive front flange loads combinations of multiple pumps might require additional pump support.

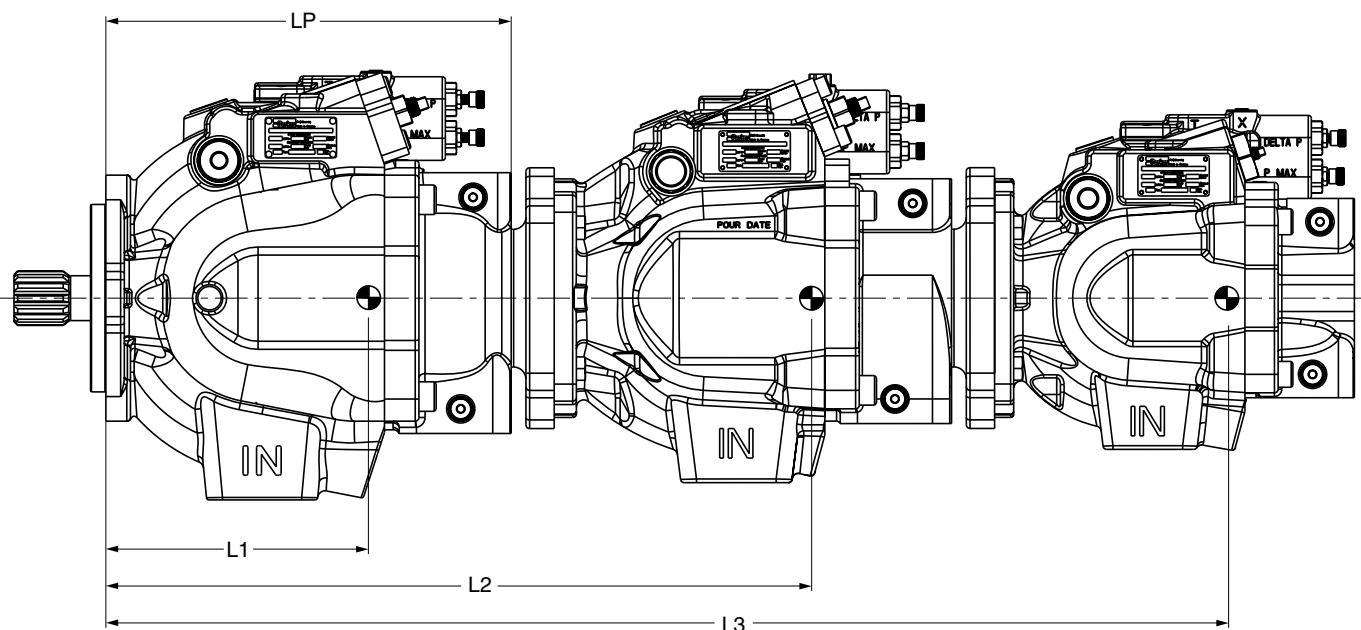

Chart 1. Maximum moment and pump dimensions

		P2060	P2075	P2105	P2145
Maximum Moment	[Nm]	197	266	425	556
Weight	[N]	358	431	618	805
Distance L1	[mm to C/G]	126	145	165	158
Distance Lp	[mm]	264	292	323	329

Chart 2. Through drive adapter plate thickness

LF		P2060	P2075	P2105	P2145
SAE - A Flange	[mm]	0	0	0	0
SAE - B Flange	[mm]	33	33	33	33
SAE - C Flange	[mm]	35	35	35	35
SAE - D Flange	[mm]	–	–	–	45.5

Resulting moment can be calculated by using the following formula:

$$\text{Moment } M = (L1*W1+L2*W2+L3*W3+...)$$

If resulting moment exceeds the maximum value given in chart 1 additional support is mandatory.

**Multiple pump combinations - Maximum thru drive torque**

		P2060	P2075	P2105/ P3105	P2145/ P3145
Torque	[Nm]	339	424	650	897

**Fluid recommendations**

- Normal mineral oil
- Premium hydraulic fluid / HLP oil
- Bio-degradable hydraulic fluid
- Synthetic hydraulic fluid
- Fire resistant fluids, water based fluids (HFC)

**Note:** Maximum system pressure reduced to 210bar for water based fluids. Bearing life time reduced to 25% by using water based fluids.

**Viscosity**

Min. viscosity for short periods:	10 mm <sup>2</sup> /s (cSt)
Normal operating viscosity:	15...40 mm <sup>2</sup> /s (cSt)
Max. viscosity for short periods:	1000 mm <sup>2</sup> /s (cSt)

**Filtration**

For maximum pump and system component functionability and life, the system should be protected from contamination by effective filtration.

Fluid cleanliness should be in accordance with ISO classification ISO 4406. The quality of filter elements should be in accordance with ISO standards.

Recommendation for filtration:

Class 21/18/14, according to ISO 4406

**Seals**

Check hydraulic fluid specification for chemical resistance of seal material.

Check temperature range of seal material and compare with max. system and ambient temperature.

N/D - NBR seals, FPM shaft seal(s) -25 ... +90 °C

B/Q - NBR seals, NBR shaft seal(s) -40 ... +90 °C

V/T - FPM seals, FPM shaft seal(s) -25 ... +115 °C

**Note:** Above limitations refer to average case drain temperature, which can be up to 20 °C higher than in the reservoir.

**Axial / Radial Loads**

Units subjected to radial loads require the installation of an outboard bearing. Axial Loads are not permitted.



# Parker Worldwide

## Europe, Middle East, Africa

**AE – United Arab Emirates,** Dubai

Tel: +971 4 8127100  
parker.me@parker.com

**AT – Austria,** Wiener Neustadt  
Tel: +43 (0)2622 23501-0  
parker.austria@parker.com

**AT – Eastern Europe,** Wiener Neustadt  
Tel: +43 (0)2622 23501 900  
parker.easteurope@parker.com

**AZ – Azerbaijan,** Baku  
Tel: +994 50 22 33 458  
parker.azerbaijan@parker.com

**BE/LU – Belgium,** Nivelles  
Tel: +32 (0)67 280 900  
parker.belgium@parker.com

**BG – Bulgaria,** Sofia  
Tel: +359 2 980 1344  
parker.bulgaria@parker.com

**BY – Belarus,** Minsk  
Tel: +375 17 209 9399  
parker.belarus@parker.com

**CH – Switzerland,** Etoy  
Tel: +41 (0)21 821 87 00  
parker.switzerland@parker.com

**CZ – Czech Republic,** Klecany  
Tel: +420 284 083 111  
parker.czechrepublic@parker.com

**DE – Germany,** Kaarst  
Tel: +49 (0)2131 4016 0  
parker.germany@parker.com

**DK – Denmark,** Ballerup  
Tel: +45 43 56 04 00  
parker.denmark@parker.com

**ES – Spain,** Madrid  
Tel: +34 902 330 001  
parker.spain@parker.com

**FI – Finland,** Vantaa  
Tel: +358 (0)20 753 2500  
parker.finland@parker.com

**FR – France,** Contamine s/Arve  
Tel: +33 (0)4 50 25 80 25  
parker.france@parker.com

**GR – Greece,** Athens  
Tel: +30 210 933 6450  
parker.greece@parker.com

**HU – Hungary,** Budaörs  
Tel: +36 23 885 470  
parker.hungary@parker.com

**IE – Ireland,** Dublin  
Tel: +353 (0)1 466 6370  
parker.ireland@parker.com

**IT – Italy,** Corsico (MI)  
Tel: +39 02 45 19 21  
parker.italy@parker.com

**KZ – Kazakhstan,** Almaty  
Tel: +7 7273 561 000  
parker.easteurope@parker.com

**NL – The Netherlands,** Oldenzaal  
Tel: +31 (0)541 585 000  
parker.nl@parker.com

**NO – Norway,** Asker  
Tel: +47 66 75 34 00  
parker.norway@parker.com

**PL – Poland,** Warsaw  
Tel: +48 (0)22 573 24 00  
parker.poland@parker.com

**PT – Portugal,** Leca da Palmeira  
Tel: +351 22 999 7360  
parker.portugal@parker.com

**RO – Romania,** Bucharest  
Tel: +40 21 252 1382  
parker.romania@parker.com

**RU – Russia,** Moscow  
Tel: +7 495 645-2156  
parker.russia@parker.com

**SE – Sweden,** Spånga  
Tel: +46 (0)8 59 79 50 00  
parker.sweden@parker.com

**SK – Slovakia,** Banská Bystrica  
Tel: +421 484 162 252  
parker.slovakia@parker.com

**SL – Slovenia,** Novo Mesto  
Tel: +386 7 337 6650  
parker.slovenia@parker.com

**TR – Turkey,** Istanbul  
Tel: +90 216 4997081  
parker.turkey@parker.com

**UA – Ukraine,** Kiev  
Tel: +380 44 494 2731  
parker.ukraine@parker.com

**UK – United Kingdom,** Warwick  
Tel: +44 (0)1926 317 878  
parker.uk@parker.com

**ZA – South Africa,** Kempton Park  
Tel: +27 (0)11 961 0700  
parker.southafrica@parker.com

## North America

**CA – Canada,** Milton, Ontario  
Tel: +1 905 693 3000

**US – USA,** Cleveland (industrial)  
Tel: +1 216 896 3000

**US – USA,** Elk Grove Village (mobile)  
Tel: +1 847 258 6200

## Asia Pacific

**AU – Australia,** Castle Hill  
Tel: +61 (0)2-9634 7777

**CN – China,** Shanghai  
Tel: +86 21 2899 5000

**HK – Hong Kong**  
Tel: +852 2428 8008

**ID – Indonesia,** Tangerang  
Tel: +62 21 7588 1906

**IN – India,** Mumbai  
Tel: +91 22 6513 7081-85

**JP – Japan,** Fujisawa  
Tel: +81 (0)4 6635 3050

**KR – South Korea,** Seoul  
Tel: +82 2 559 0400

**MY – Malaysia,** Shah Alam  
Tel: +60 3 7849 0800

**NZ – New Zealand,** Mt Wellington  
Tel: +64 9 574 1744

**SG – Singapore**  
Tel: +65 6887 6300

**TH – Thailand,** Bangkok  
Tel: +662 717 8140

**TW – Taiwan,** New Taipei City  
Tel: +886 2 2298 8987

**VN – Vietnam,** Ho Chi Minh City  
Tel: +84 8 3999 1600

## South America

**AR – Argentina,** Buenos Aires  
Tel: +54 3327 44 4129

**BR – Brazil,** Cachoeirinha RS  
Tel: +55 51 3470 9144

**CL – Chile,** Santiago  
Tel: +56 2 623 1216

**MX – Mexico,** Toluca  
Tel: +52 72 2275 4200

### EMEA Product Information Centre

Free phone: 00 800 27 27 5374

(from AT, BE, CH, CZ, DE, DK, EE, ES, FI, FR, IE, IL, IS, IT, LU, MT, NL, NO, PL, PT, RU, SE, SK, UK, ZA)

### US Product Information Centre

Toll-free number: 1-800-27 27 537

www.parker.com

